

**CHAMBERLAIN**<sup>®</sup>

<sup>®</sup>

# merlin

more than magic

[www.chamberlainanz.com](http://www.chamberlainanz.com)

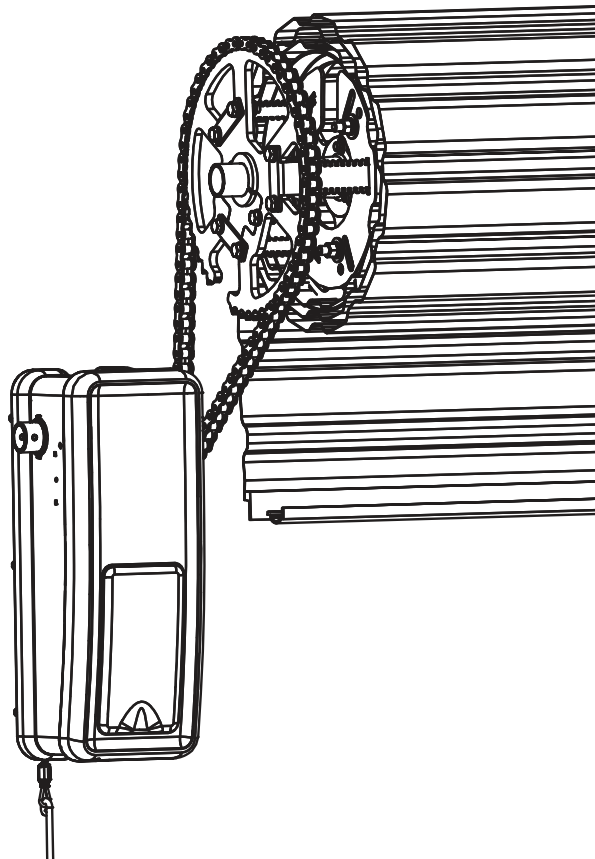

## MJ3800R

**Light Duty Commercial & Residential Door Opener**

**Installation and Operating Instructions**

**Owners Copy: Please keep these instructions for future reference**



This manual contains **IMPORTANT SAFETY** information  
**DO NOT PROCEED WITH THE INSTALLATION BEFORE READING THOROUGHLY**



**N2966**

# START BY READING THESE IMPORTANT SAFETY INSTRUCTIONS

## WARNING

- Failure to comply with the following instructions may result in serious personal injury or property damage.
- Read and follow all instructions carefully.
- The garage door opener is designed and tested to offer safe service provided it is installed and operated in strict accordance with the instructions in this manual.



These safety alert symbols mean **WARNING**: A possible risk to personal safety or property damage exists.



**Keep garage door balanced.** Do not let the garage door opener compensate for a binding or sticking garage door. Sticking, binding or unbalanced doors must be repaired before installing this opener.



**Do not wear rings, watches or loose clothing** while installing or servicing a garage door opener.



**Frequently examine the door installation**, in particular cable, springs and mountings for signs of wear, damage or imbalance. Do not use if repair or adjustment is needed since springs and hardware are under extreme tension and a fault can cause serious personal injury.



To avoid serious personal injury from entanglement, **remove all ropes, chains and locks connected to the garage door** before installing the door opener.



**Installation and wiring** must be in compliance with your local building and electrical codes.



**The safety reverse system test is very important.** Your garage door **MUST** reverse on contact with a 40mm obstacle placed on the floor. Failure to properly adjust the opener may result in serious personal injury from a closing garage door. **Repeat the test once a month and make any necessary adjustments.**



This appliance is not intended for use by persons (including children) with reduced physical, sensory or mental capabilities, or lack of experience and knowledge, unless they have been given supervision or instruction concerning use of the appliance by a person responsible for their safety.



**This opener should not be installed in a damp or wet space exposed to weather.**



**The opener must not be used on a wicket door (door within a door).**



**The Protector System™ must be used for all installations where the closing force as measured on the bottom of the door is over 400N (40kgf).** Excessive force will interfere with the proper operation of the safety reverse system or damage the garage door.



**After installation, ensure that the parts of the door do not extend over public footpaths or roads.**



Install the wireless wall button (or any additional wall control) **in a location where the garage door is visible, at a height of at least 1.5m and out of the reach of children. Do not allow children to operate push button(s) or transmitter(s).** Serious personal injury from a closing garage door may result from misuse of the opener.



**Permanently fasten the Warning Labels in prominent places**, adjacent to wall controls and manual release mechanisms as a reminder of safe operating procedures.



**Activate opener only when the door is in full view, free of obstructions and the opener is properly adjusted. No one should enter or leave the garage while the door is in motion.**



**Do not allow children to play near the door, or multi function door controls.**



**Disconnect electric power, including Evercharge™ battery back up unit to the garage door opener before making repairs or removing covers.**

## KEEP THESE INSTRUCTIONS

**NOTE:** If your garage has no service entrance door, a CM1702 outside quick release must be installed. This accessory allows manual operation of the garage door from outside in case of power failure.

CONTENTS	PAGE
SAFETY INSTRUCTIONS . . . . .	2
CARTON INVENTORY . . . . .	3
ACCESSORIES . . . . .	3
SPECIFICATION . . . . .	4
TOOLS REQUIRED . . . . .	4
PREPARE & TEST THE DOOR . . . . .	4
DOOR REQUIREMENTS . . . . .	5
ASSEMBLY . . . . .	5-6
INSTALLATION . . . . .	7-12
CONNECT ELECTRIC POWER . . . . .	10
MULTI-FUNCTION DOOR CONTROL . . . . .	10

INSTALL THE PROTECTOR SYSTEM . . . . .	12-13
AUTO CLOSE . . . . .	13
ADJUSTMENT . . . . .	14-17
WIRELESS PROGRAMMING . . . . .	18-19
REPAIR PARTS . . . . .	20
DIAGNOSTIC CHART . . . . .	21
TROUBLESHOOTING . . . . .	22
CARE OF YOUR OPENER . . . . .	23
OPERATION OF YOUR OPENER . . . . .	23
WARRANTY . . . . .	24

# CARTON INVENTORY

Your door opener is packaged in one carton which contains the opener and the parts illustrated below. Note that accessories will depend on the model purchased. If anything is missing, carefully check the packing material.

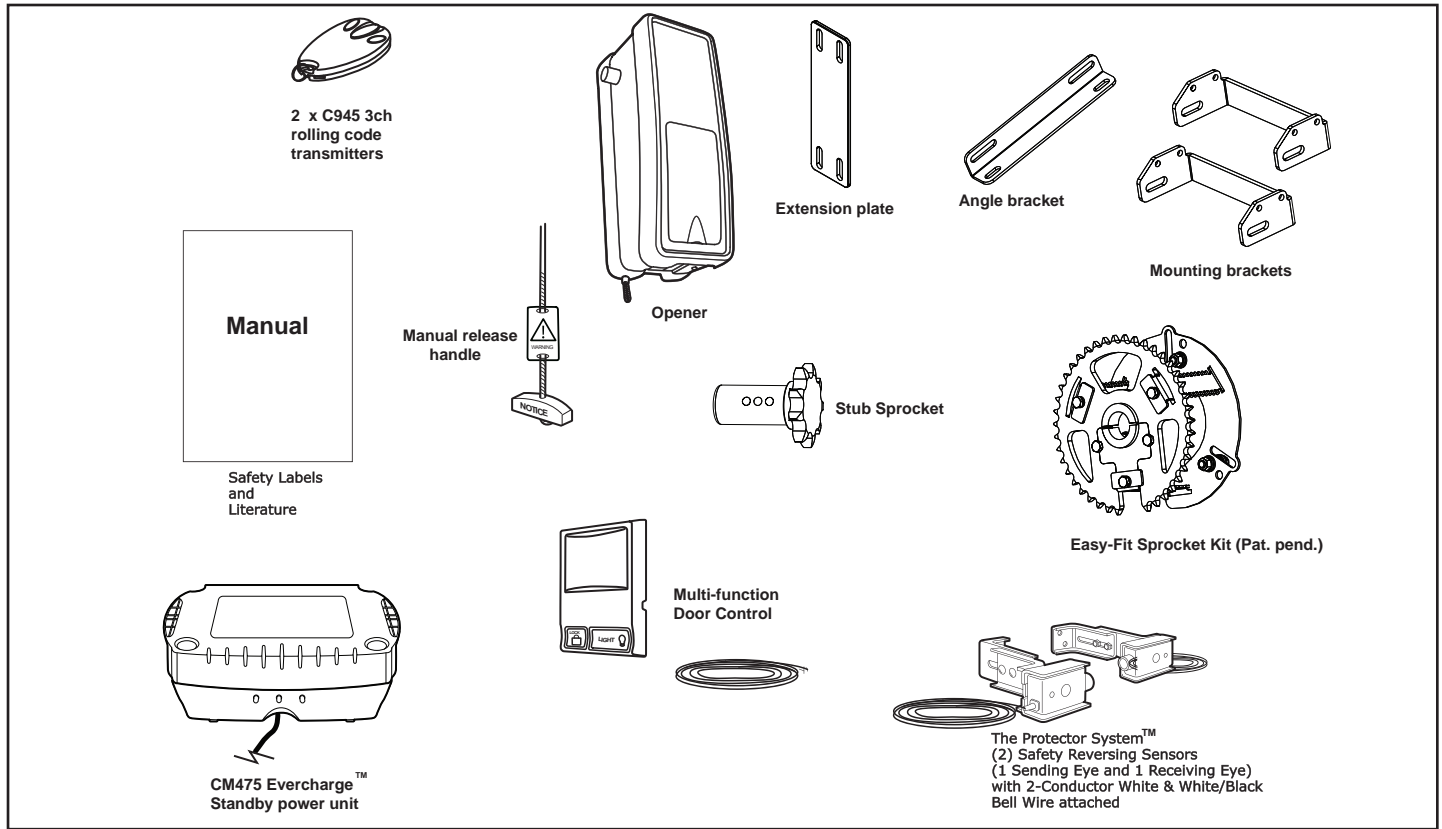

# ACCESSORIES

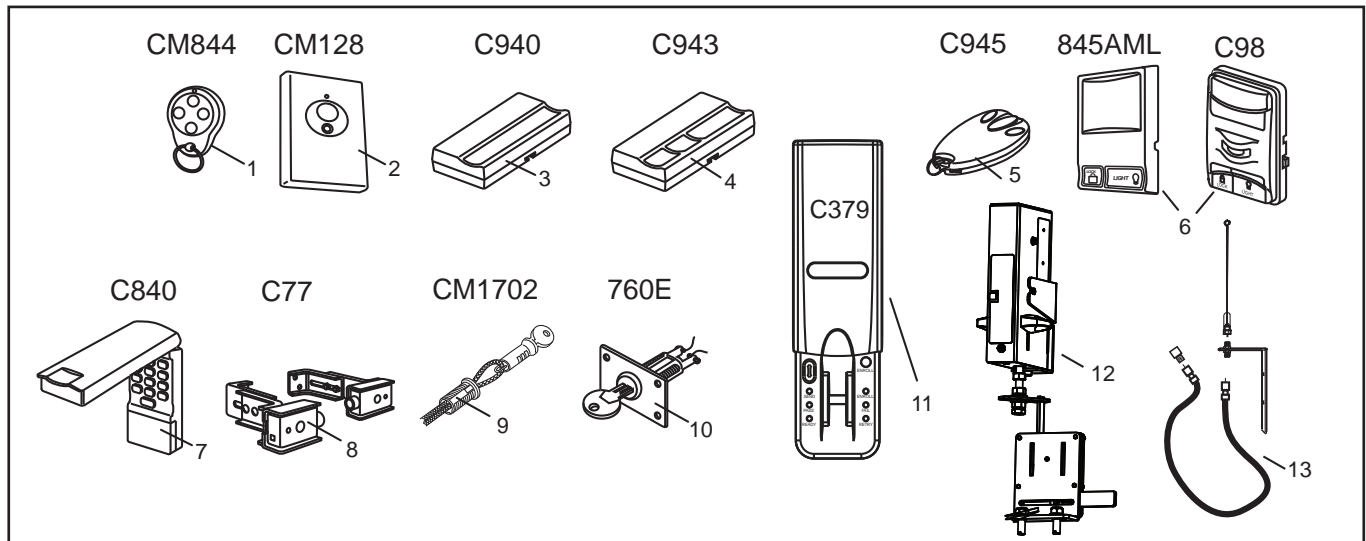

- |                                  |   |                    |                                    |
|----------------------------------|---|--------------------|------------------------------------|
| (1) Model CM844                  | 4 Channel transmitter   | (7) Model C840     | Keyless Entry System               |
| (2) Model CM128                  | Wireless Wall Button  | (8) Model C77      | The Protector System™              |
| (3) Model C940                   | 1 Channel visor transmitter                                   | (9) Model CM1702   | Quick Release Lock                 |
| (4) Model C943                   | 3 Channel visor transmitter                                   | (10) Model 760E    | Outside Keyswitch                  |
| (5) Model C945                   | 3 Channel mini transmitter                                    | (11) Model C379    | Wireless Fingerprint Access System |
| (6) Model 845AML<br>or Model C98 | Multi-Function Door Control<br>Motion Detecting Control Panel | (12) Model SRDLK01 | Solenoid roller door lock          |
|                                  |   | (13) Model ANT4X-1 | 433MHz Antenna, cable and adaptor  |

## PREPARING YOUR DOOR

### BEFORE YOU BEGIN:

- Disable locks.
- Remove any ropes connected to door.
- **Complete the following test** to make sure your door is balanced and is not sticking or binding:

1. Lift the door about halfway as shown. Release the door. If balanced, it should stay in place, supported entirely by its springs. Repeat this test in a number of different positions to ensure the door is correctly balanced.

**NOTE: The spring should hold the door at any open position without creeping up or down.**

2. Raise and lower the door to see if there is any binding or sticking.

**IF YOUR DOOR BINDS, STICKS OR IS OUT OF BALANCE, CALL A TRAINED DOOR SYSTEMS TECHNICIAN.**

3. The installer is to ensure that the temperature range is suitable for the installation.

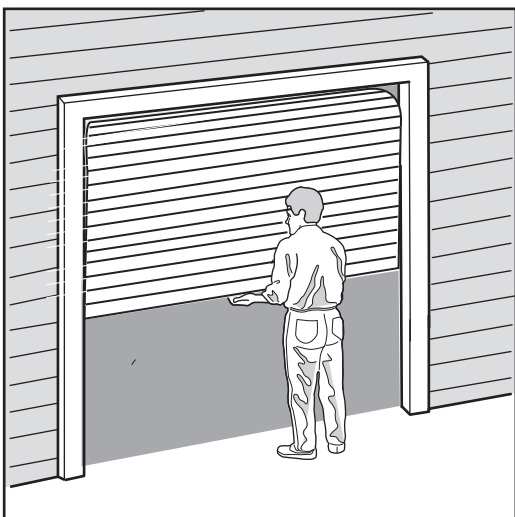

### TOOLS NEEDED

During assembly, installation and adjustment of the opener, instructions will call for hand tools as illustrated below.

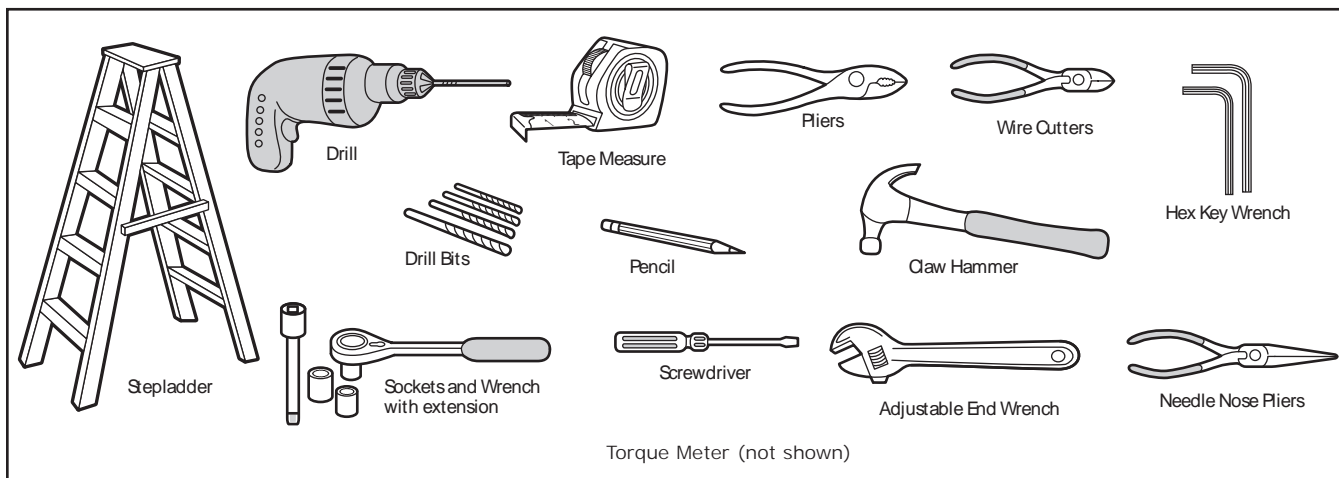

## **⚠ WARNING**

To prevent possible **SERIOUS INJURY** or **DEATH**:

- **ALWAYS** call a trained door systems technician if door binds, sticks or is out of balance. An unbalanced door may not reverse when required.
- **NEVER** try to loosen, move or adjust door, door springs, cables, pulleys, brackets or their hardware, **ALL** of which are under **EXTREME** tension.
- Disable **ALL** locks and remove manual opening chain if attached to the door **BEFORE** installing and operating the door opener to avoid entanglement.
- This device is not intended for use by small children or infirmed persons without supervision.
- young children should **NOT** be permitted to play with the opener or transmitters.

## **CAUTION**

To prevent damage to door and opener:

- **ALWAYS** disable locks **BEFORE** installing and operating the opener.

## **SPECIFICATIONS**

**Volts:** 230-240 ~ V 50 Hz

**Power:** 145 Watts

**Rated Load:** 63Nm @ drum

**Fmax:** 253Nm @ drum

**Max door height:** 6.0m

**Max door width:** 5.5m

**Max area:** 25m<sup>2</sup>

**Temperature range:** -20° C to 55° C

**Please note this opener contains both imperial and metric fasteners.**

---

## DOOR REQUIREMENTS

Survey the area to see if any of the conditions below apply to your installation. Additional materials may be required. You may find it helpful to refer back to this page as you proceed with the installation of your opener. Depending on your requirements, there are several installation steps which may call for materials or hardware not included in the carton.

This opener is compatible with:

- One piece spring balanced roller doors able to hold still at all positions of the door
- Doors up to 6.0m high
- Doors up to 5.5m (18') wide
- Doors up to 25m<sup>2</sup>
- Door axle diameter must not exceed 35mm

Considerations:

- Review or inspect proposed installation area. Opener can be installed on left or right side of door. Select the side that meets the requirements listed below.
- Must have a drum wheel comprising three mounting holes corresponding to the base plate provided (suits most brands of commercial roller door).
- An electric outlet is required within 1.8m (6') of the installation area. If outlet does not exist, contact a qualified electrician.
- Depending upon the construction, extension brackets may be needed to install safety reversing sensors.
- Any gap between the floor and the bottom of the door must not exceed 6mm, otherwise the safety reversal system may not work properly.

---

## ASSEMBLY STEP 1

Before installing the unit, attach the mounting brackets correctly to the unit using the provided screws (figure 1). Once attached the unit is ready to be wall mounted (figure 2).

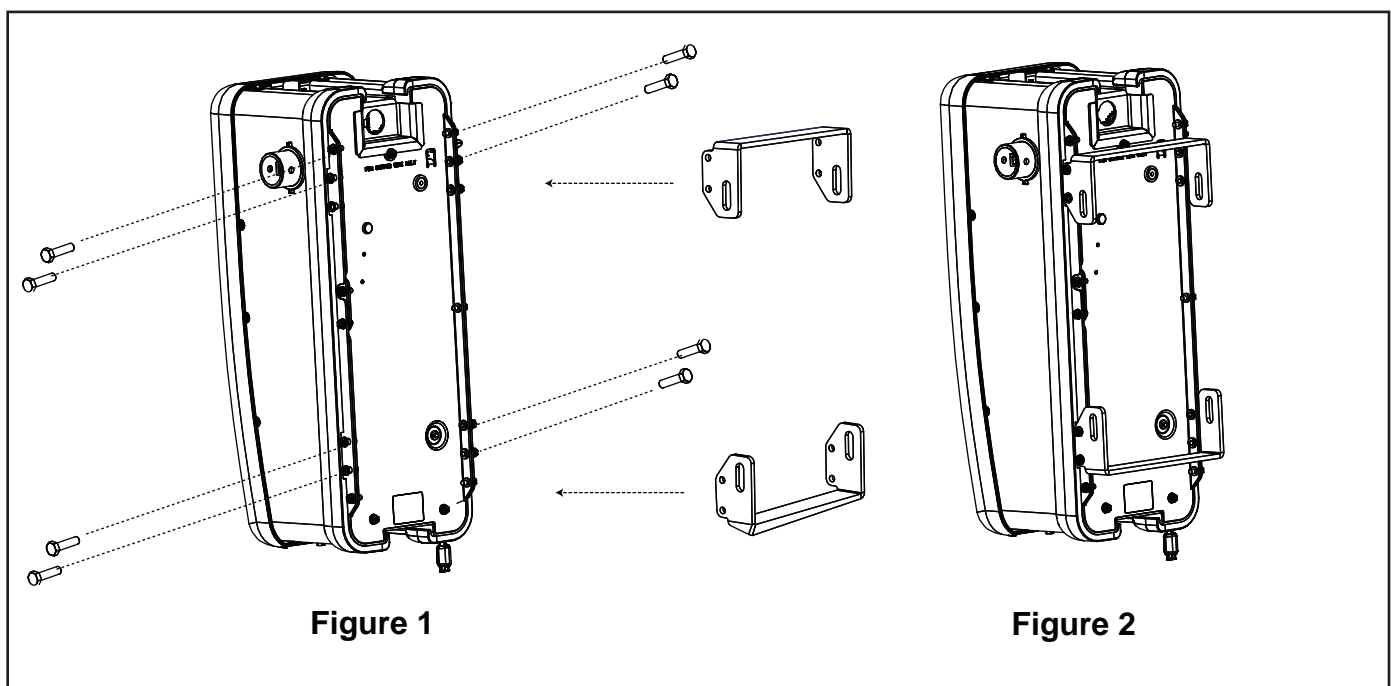

## CHAIN ALIGNMENT CONSIDERATION

Before installing, consider the relationship between the opener and door in terms of the chain connection. Clearances are indicated below to demonstrate the range of sprocket positions available. Choose your opener mounting location based on the drawing below.

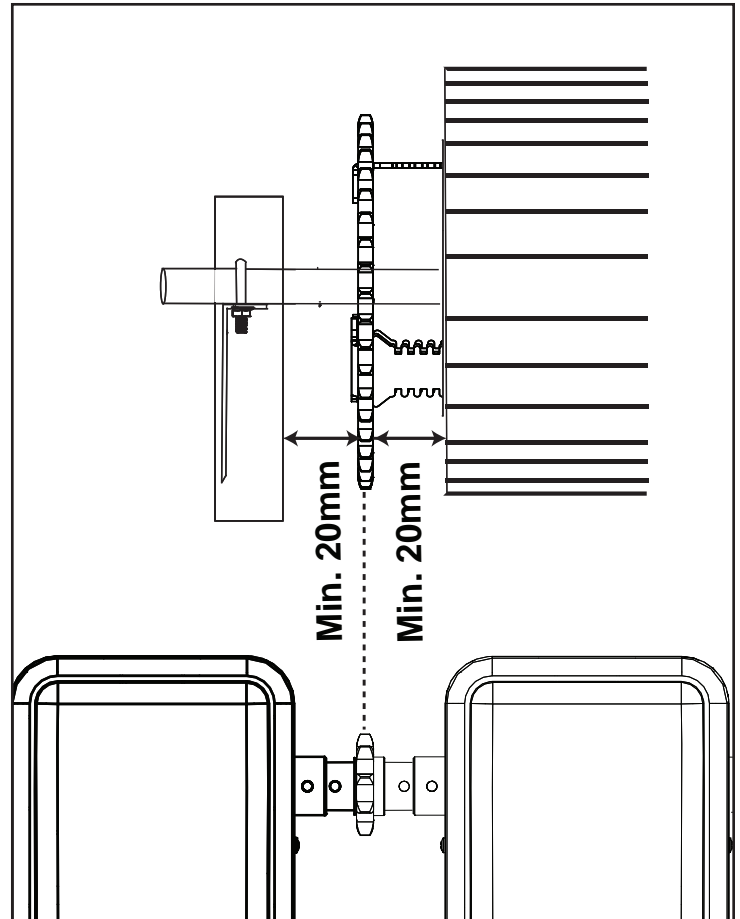
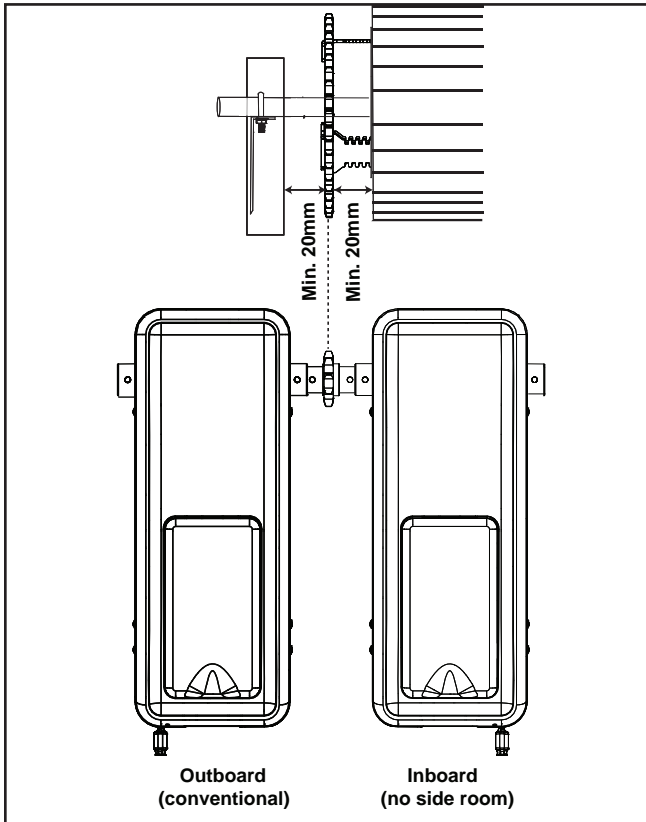

## INSTALLATION

### IMPORTANT INSTALLATION INSTRUCTIONS

#### **WARNING**

#### To reduce the risk of SEVERE INJURY or DEATH:

1. READ AND FOLLOW ALL INSTALLATION WARNINGS AND INSTRUCTIONS.
2. Install door opener ONLY on properly balanced and lubricated door. An improperly balanced door may not reverse when required and could result in SEVERE INJURY or DEATH.
3. ALL repairs to cables, spring assemblies and other hardware MUST be made by a trained door systems technician BEFORE installing opener.
4. Disable ALL locks and remove ALL ropes connected to the door BEFORE installing opener to avoid entanglement.
5. Mount emergency release handle no higher than 1.8m above floor.
6. NEVER connect the door opener to power source until instructed to do so.
7. NEVER wear watches, rings or loose clothing while installing or servicing opener. They could be caught in the door or opener mechanisms.
8. Install wall-mounted door control:
  - within sight of the door.
  - out of reach of children at minimum height of 1.5 m.
  - away from ALL moving parts of the door.
9. Place entrapment warning label on wall next to multi-function door control.
10. Place manual release/safety reverse test label in plain view on inside of the door.
11. Upon completion of installation, test safety reversal system. Door MUST reverse on contact with a 40mm (1 1/2") high obstacle placed on the floor.

# INSTALLATION STEP 1

## MOUNTING THE UNIT

When mounting the unit there are several installation combinations all dependent on clearance and accessibility. Always mount to the side of the unit at which the sprocket will be fitted.

**Note: the wall angle below is shown in a particular orientation. This may vary from door to door.**

### DIRECT EXISTING ANGLE MOUNT

The unit can be mounted directly to an existing angle where suitable.

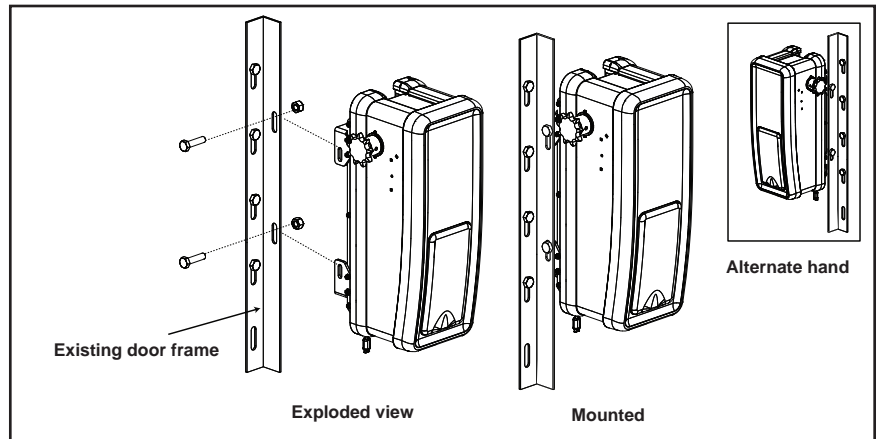

### INDIRECT EXISTING ANGLE MOUNT

When there is not enough clearance to allow for direct existing angle mount the extension plate can be used to provide sufficient stand off clearance.

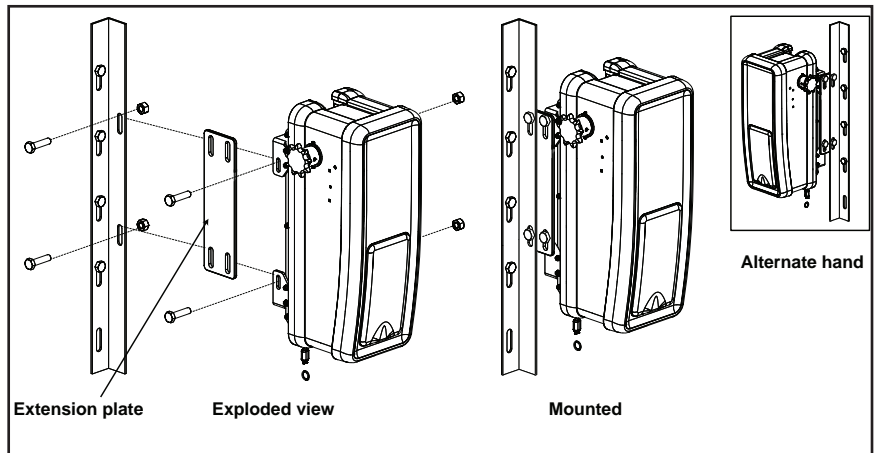

### ANGLE BRACKET - WALL MOUNT

Where possible the unit can be attached to the angle bracket then onto the wall, or vice versa.

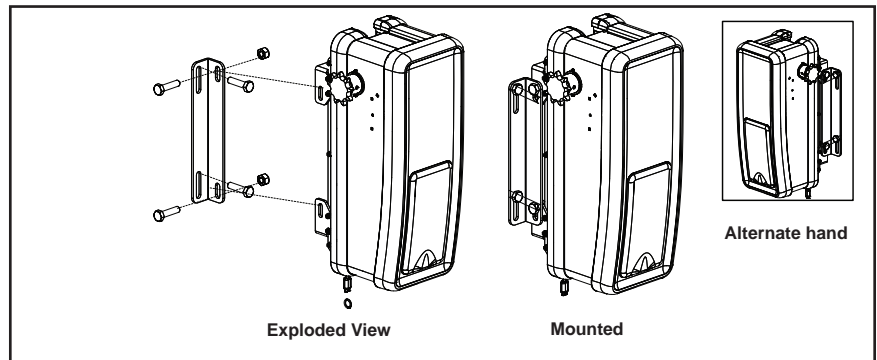

### ANGLE & EXTENSION WALL MOUNT

If more stand off clearance is required, the extension plate can be used between the angle bracket and unit.

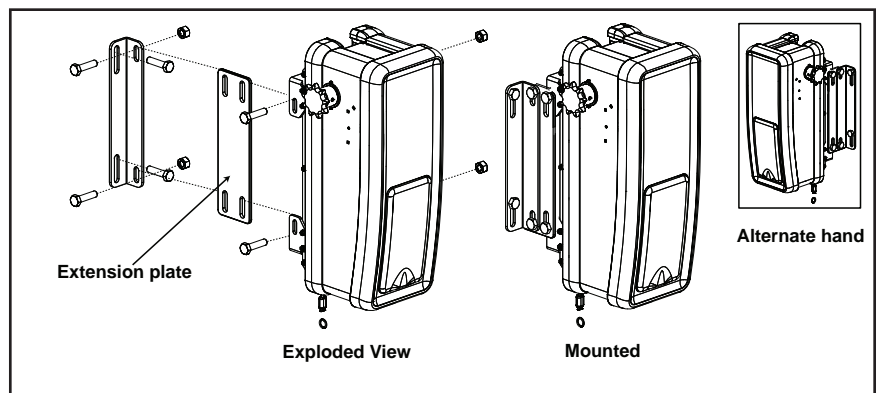

## INSTALLATION STEP 2

### EASY-FIT SPROCKET INSTALLATION

1. Identify matching hole patterns in drum wheel and base plate, then fasten the 3 x 3/8" hex bolts to the corresponding holes in the drum wheel using the large flat washers and spring washers as shown in figure 1. Ensure that the 3/8" hex nuts are fastened tightly.

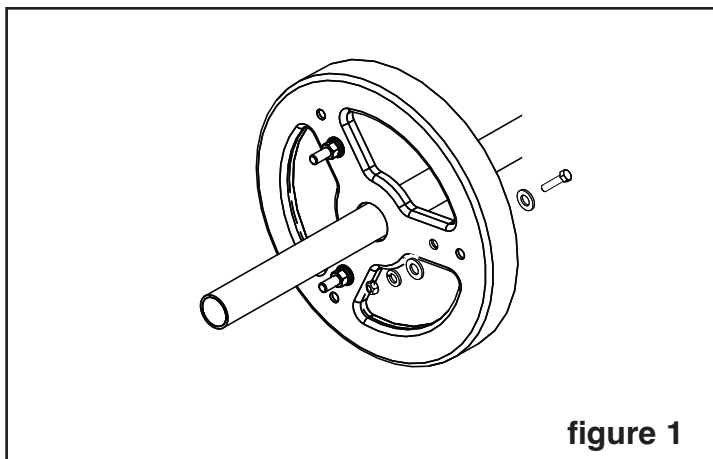

figure 1

2. Place large flat washers on the protruding bolts and fasten base plate to the bolts using large flat washers, spring washers, and 3/8" hex nuts as shown in figure 2. When selecting the orientation of the base plate in relation to the drum wheel ensure there is enough clearance between the slots for the drive spacer and the spokes of the drum wheel.

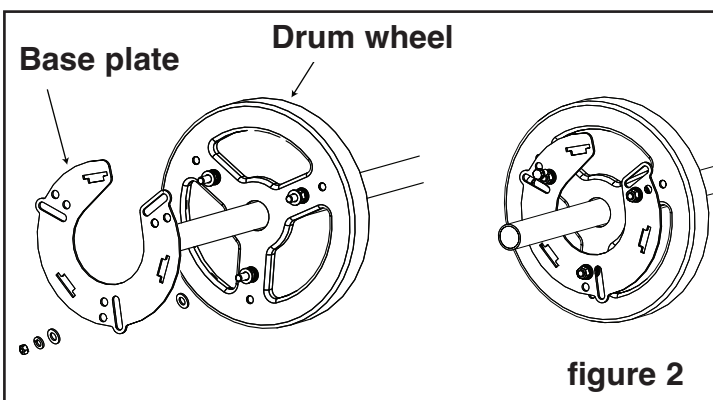

figure 2

3. Slide sprocket incl. half bush over door shaft and insert bush retainer incl. half bush and fasten to sprocket using M8 bolts and M8 Nyloc nuts as shown in figure 3. Ensure nuts are firmly tightened.

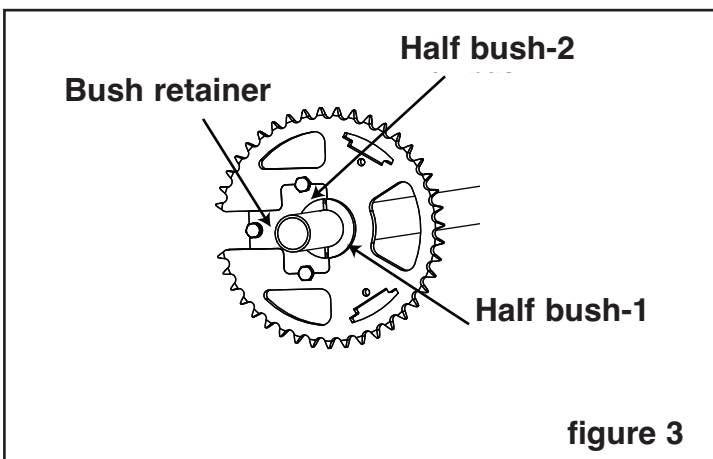

figure 3

4. Attach to sprocket using M8 x 16 Hex bolt and spring washer as shown in figure 4.

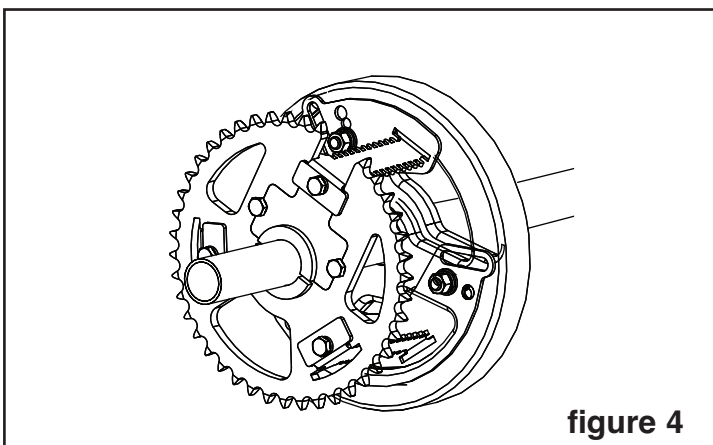
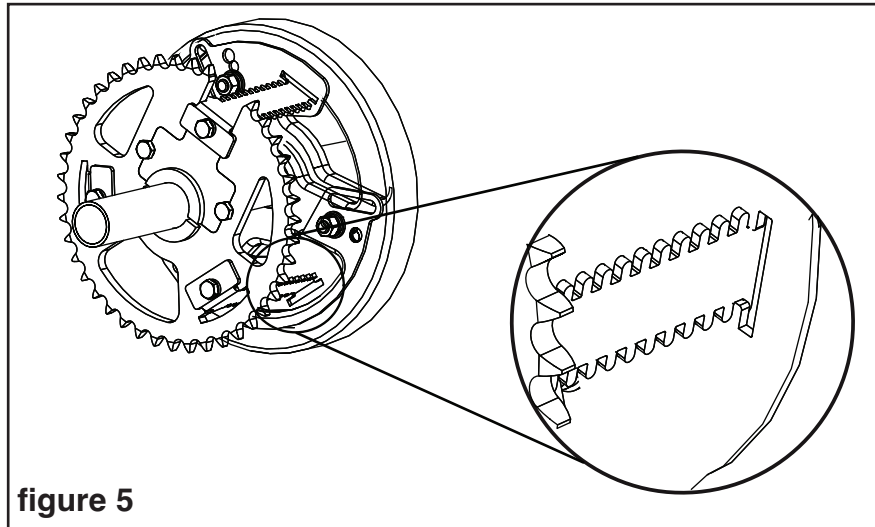

figure 4



## INSTALLATION STEP 2 (CONTINUED)

5. Loosely attach the two remaining drive spacers to the sprocket as shown in figure 5, using M8 x16 bolts and spring washers. The slots should correspond in the base plate to achieve desired distance between sprocket and base plate, see figure 5. Ensure correct fit and spacing of all drive spacers, then firmly tighten all loose connections. This completes installation of the Chamberlain Easy Fit Sprocket Kit (Pat. pend.).



## CHAIN AND SPROCKET LINKAGE

Fit and align the stub sprocket to the unit and install the drive chain. The drive chain should be tensioned using the weight of the motor unit to remove slack. Do not force the opener downward to tension the chain.

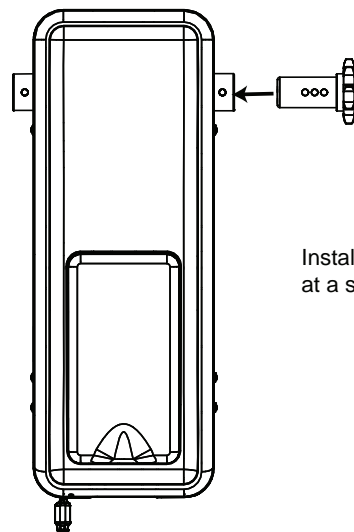

Install the stub sprocket  
at a suitable position

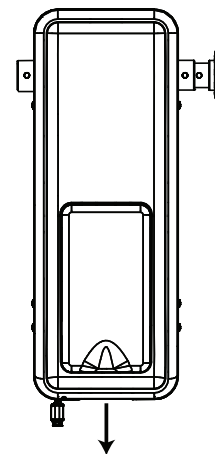

Use weight of opener to tension  
chain, then tighten mounting  
bolts. Do not force the opener  
downward.

## INSTALLATION STEP 3

### ATTACH THE EMERGENCY RELEASE ROPE AND HANDLE

- Thread one end of the rope through the hole in the top of the red handle so "NOTICE" reads right side up as shown. Secure with an overhand knot at least 25mm (1") from the end of the rope to prevent slipping.
- Thread the other end of the rope through the loop in the emergency release cable.
- Adjust rope length so the handle is no higher than 1.8m (6') above the floor. Secure with an overhand knot.

**NOTE:** If it is necessary to cut the rope, heat seal the cut end to prevent unraveling.

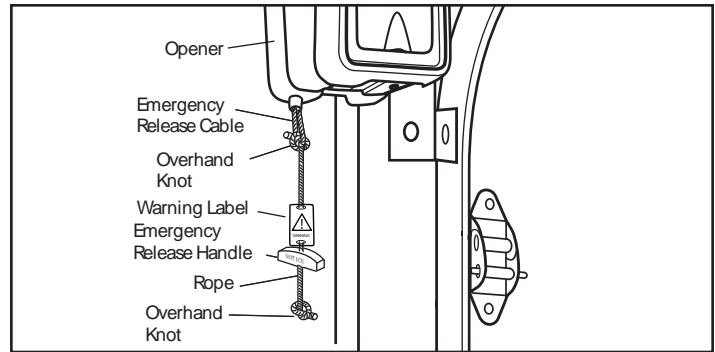

## INSTALLATION STEP 4

### ELECTRICAL REQUIREMENTS

To avoid installation difficulties, do not run the opener at this time.

To reduce the risk of electric shock, your door opener has a grounding type plug with a third grounding pin. This plug will only fit into a grounding type outlet. If the plug doesn't fit into the outlet you have, contact a qualified electrician to install the proper outlet.

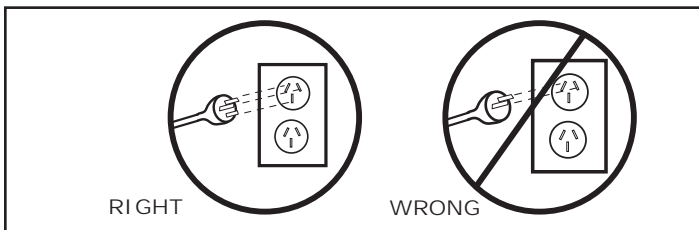

## INSTALLATION STEP 5

### INSTALLING THE MULTI-FUNCTION WALL CONTROL

**Note:** any connection to your MJ3800R should be voltage free and Normally open.

There are 2 screw terminals on the back of the multi-function door control. Strip about 6mm of insulation from bell wire. Separate wires enough to connect the white/red wire to R terminal screw 1 and the white wire to W terminal screw 2. Fasten the multi-function door control to an inside garage wall with sheet metal screws provided. Drill 4mm holes and use anchors if installing into plasterboard wall. A convenient place is beside the service door and out of reach of children. Run the bell wire up the wall and across the ceiling to the garage door opener. Use insulated staples to secure wire. The receiver quick connect terminals are located on the control board. Connect the bell wire to the terminals as follows: white/red to red and white to white.

## ⚠ WARNING

To prevent possible SERIOUS INJURY or DEATH from electrocution or fire:

- Be sure power is not connected to the opener, and disconnect power to circuit BEFORE removing cover.
- Door installation and wiring MUST be in compliance with ALL electrical and building codes.
- NEVER use an extension cord, 2-wire adaptor or change plug in any way to make it fit outlet. Be sure the opener is grounded.
- If the supply cord is damaged, it must be replaced by the manufacturer or it's service agent or similarly qualified person in order to avoid hazard.

## ⚠ WARNING

To prevent possible SERIOUS INJURY or DEATH from a falling door:

- If possible, use emergency release handle to disengage door ONLY when door is CLOSED. Weak or broken springs or unbalanced door could result in an open door falling rapidly and/or unexpectedly.
- NEVER use emergency release handle unless the doorway is clear of persons and obstructions.

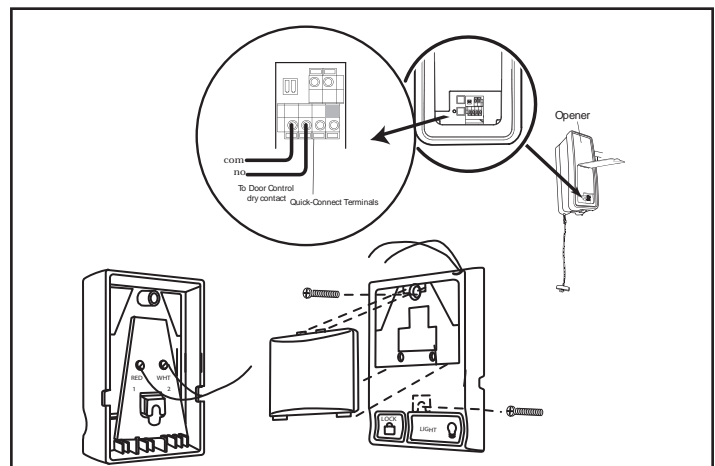

## INSTALLATION STEP 6

### INSTALLING THE WIRELESS WALL BUTTON (CM128) (OPTIONAL ACCESSORY)

*Control must be mounted out of the reach of children at a height of 1.5m with an unobstructed view of the door.*

- Ensure your MJ3800R opener is switched off whilst installing your wireless door control to prevent accidental activation.
- Remove the cover from the CM128.
- Mount CM128 as shown using the screws provided if mounting into a wall box (not provided).
- If mounting directly on the wall use wall anchors (provided) to fix unit to the plasterboard wall.
- Replace the cover plate and **affix the warning label adjacent to the wall controller.**

*Fix the emergency door release label adjacent to the opener.*

## WARNING

### CONNECT ELECTRIC POWER

TO AVOID INSTALLATION DIFFICULTIES, DO NOT RUN THE GARAGE DOOR OPENER UNTIL INSTRUCTED TO DO SO.

Connect to properly fused and earth power outlet.

## INSTALLATION STEP 7

### MOUNTING THE EVERCHARGE STANDBY POWER UNIT (SPU)

- The SPU can be mounted to either the ceiling or a wall within .9 m (3') of the opener.
- Position the SPU as desired to a structural support (ceiling joist or wall stud).
- Attach the SPU to the support using the mounting holes on either side of the SPU.
- Secure the SPU using the 1-1/2" lag screws (2) provided with the SPU unit.
- Connect the SPU cord into the connector on the bottom of the opener.
- Follow all instructions included with the CM475 unit to test for proper operation and testing of the SPU.

## WARNING

Disconnect power to the opener whilst installing this accessory to prevent accidental activation.  
Locate minimum 1.5m above the floor.

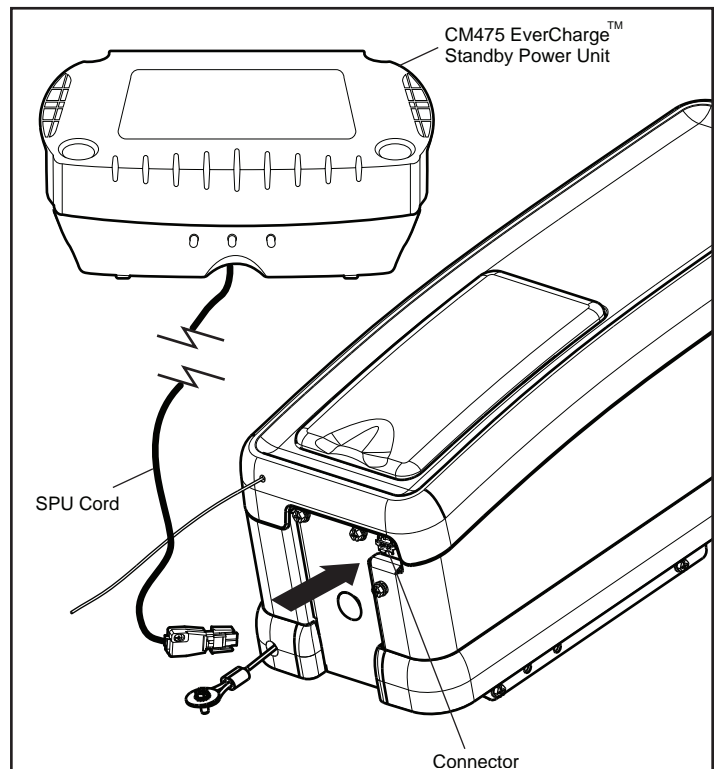
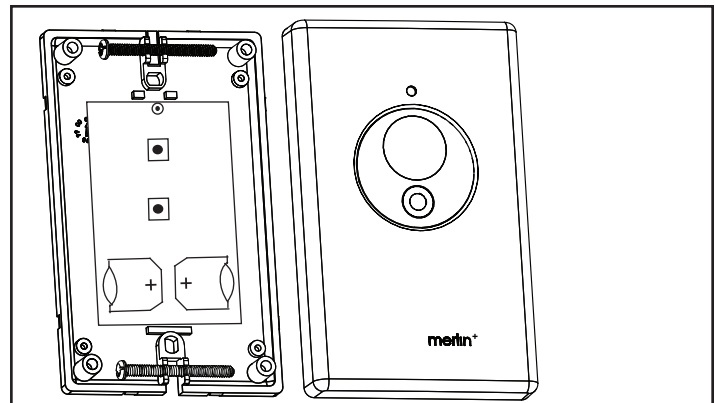

## INSTALLATION STEP 8

### INSTALL THE PROTECTOR SYSTEM™

When installed the safety reversing sensor *must* be connected and aligned correctly before the door opener will move in the down direction. This safety device is provided for your safety and **MUST** not be disabled.

### INSTALLING THE BRACKETS

Be sure power to the opener is disconnected.

Figures 1 and 2 show recommended assembly of bracket(s) and "C" wrap based on the *wall* installation of the sensors on each side of the door shown above, or on the *door tracks* themselves. Figures 4, 5 & 6 show variations which may fit your installation requirements better. **Make sure the wraps and brackets are aligned so the sensors will face each other across the door.**

- Connect each assembly to a slotted bracket, using the hardware shown. **Note alignment of brackets for left and right sides of the door.** Finger tighten the lock nuts.
- Use bracket mounting holes as a template to locate and drill (2) (4.8mm) diameter pilot holes on both sides of the door, (100mm). Max height is (100mm).
- Attach bracket assemblies with 1/4"x1-1/2" lag screws as shown.
- Adjust right and left side bracket assemblies to the same distance out from mounting surface. Make sure all door hardware obstructions are cleared. Tighten the nuts securely.
- Centre each sensor unit in a "C" wrap with lenses pointing toward each other across the door.
- Secure sensors with the hardware shown in Figure 6. Finger tighten the wing nut on the *receiving* eye to allow for final adjustment. Securely tighten the *sending* eye wing nut.
- Run wires from both sensors to the opener as shown on page 13. Use insulated staples to secure the wire to the wall and ceiling.
- Connect both sets of wires to the opener terminals as shown page 13.
- Plug in the opener. If your opener has the Multi-Function Door Control, make sure the Lock Feature is *off*. Red indicator lights in both the sending and receiving eyes will *glow* if wiring connections and alignment are correct.

If the indicator lights are *flashing* (and the invisible light beam path is not obstructed), alignment is required.

- Loosen the receiving eye wing nut to allow slight rotation of unit. Adjust sensor vertically and/or horizontally until the red indicator light *glows*.
- When indicator lights are glowing in both units, tighten the wing nut in the receiving eye unit.

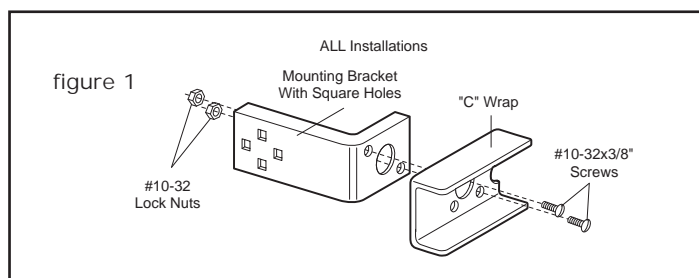

## ⚠ WARNING

Be sure power is not connected to the door opener **BEFORE** installing the safety reversing sensor.

To prevent **SERIOUS INJURY** or **DEATH** from a closing door:

- Correctly connect and align the safety reversing sensor. This required safety device **MUST NOT** be disabled.
- Install the safety reversing sensor so beam is **NO HIGHER** than 100mm (4") above the floor.

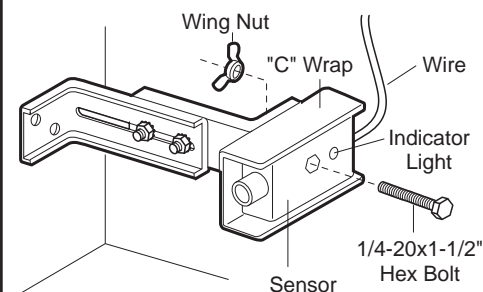
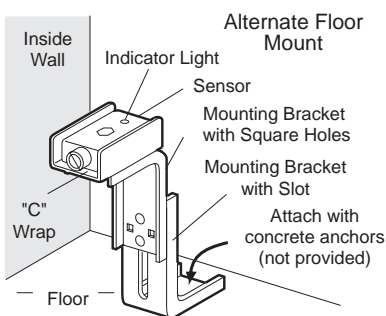
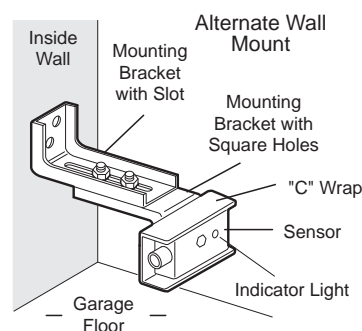
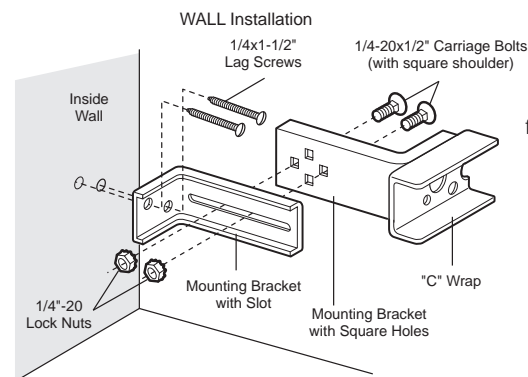

## WIRING THE SAFETY REVERSING SENSORS

- Run the wires from both safety reversing sensors to the opener. Use insulated staples to secure wire to wall and ceiling.
- Strip 11mm (7/16") of insulation from each set of wires. Separate white and white/black wires sufficiently to connect to the opener quick-connect terminals: white to white and white/black to grey (shown right).

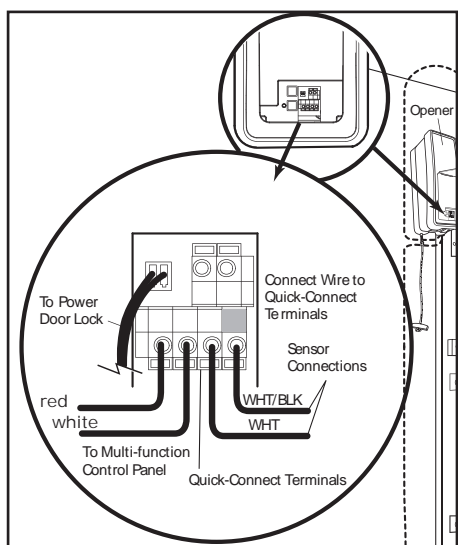

## USING THE MULTI-FUNCTION DOOR CONTROL

### THE MULTI-FUNCTION DOOR CONTROL

Press the actuator button to open or close the door. Press again to reverse the door during the closing cycle or to stop the door while it's opening.

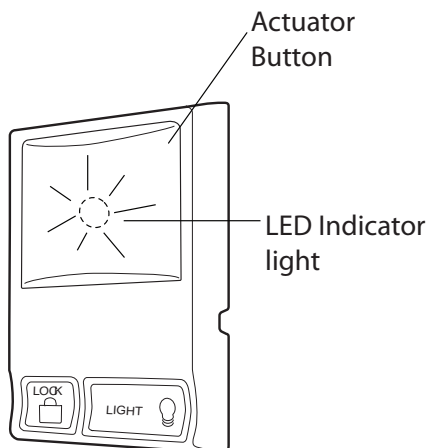

### Light feature



The Light function is not available with the MJ3800R.

### Lock feature



Designed to prevent operation of the door from hand-held transmitters whilst still allowing the door to open and close from the Door Control, the Outdoor Key Switch and the Keyless Entry Accessories. To activate, press and hold the Lock button for 2 seconds.

To turn off, press and hold the Lock button again for 2 seconds. The Lock feature will also turn off whenever the "learn" button on the opener panel is activated.

**Note: This feature does not operate the Powered door lock.**

## TROUBLESHOOTING THE SAFETY REVERSING SENSORS

1. If the *sending eye* indicator LEDs are both flashing after installation, check for:
  - Electric power to the opener.
  - A short in the white or white/black wires. These can occur at staples, or at opener connections.
  - Incorrect wiring between safety reversing sensors and opener.
  - A broken wire.
2. If the sending eye indicator light *glows steadily* but the receiving eye indicator light doesn't:
  - Check alignment.
  - Check for an open wire to the *receiving eye*.
3. If the *receiving eye* indicator light is dim, realign either sensor.

**NOTE: When the invisible beam path is obstructed or misaligned while the door is closing, the door will reverse. If the door is already open, it will not close and the LED indicator light will flash 10 times. See page 21.**

## AUTOMATIC CLOSE TIMER FUNCTION

**Note:** Requires the Chamberlain Protector System™ (IR-sensors) to be installed. If the Protector System™ (IR-sensors) is installed only to enable the timer to close function (first time), install sensors, close the garage door and wait for 5 minutes.

A Multi-function Door Control is required to enable and disable the auto-close function.

**Enable:** Push and hold lock button on the Multi-function Door Control until the electric lock toggles twice. Release the lock button, at the same time watch the LED light in the center of the actuator button from the Multi-function Door Control.

- 1x flash 10 seconds Auto-Close
- 2x flash 45 seconds Auto-Close
- 3x flash 2 minutes Auto-Close
- 4x flash 3 minutes Auto-Close
- 5x flash OFF Auto-Close

Factory setting is OFF. Repeat the procedure until the Multi-function Door Control shows the required number of flashes.

### ⚠ WARNING

Auto close is NOT recommended for households with young children.

### ⚠ WARNING

Door may operate unexpectedly, therefore do not allow anything to stay in the path of the door.

## ADJUSTMENT STEP 1

### PROGRAM THE TRAVEL LIMITS

*Travel limits regulate the points at which the door will stop when moving up or down. Follow the steps below to set the limits.*

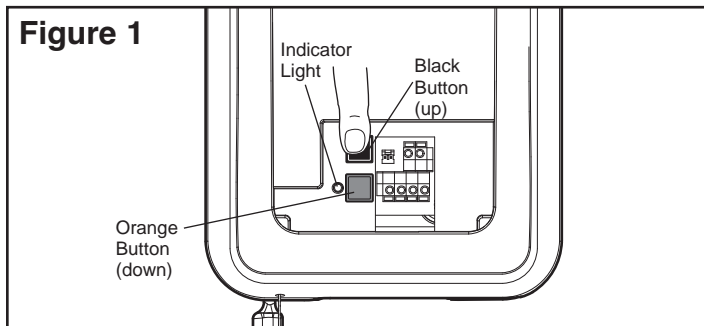

#### **To program the travel limits:**

Adjust the position of the door by using the black and orange buttons. Black moves the door UP (open) and orange moves the door DOWN (close).

1. **Setting the UP position:** Press and hold the black button until the yellow indicator light starts flashing slowly then release.
2. Push and hold the black button until the door reaches the desired UP (open) position (Figure 2).

**NOTE: Check to be sure the door opens high enough for your vehicle to pass under.**

3. Push the transmitter, wireless wall button or multi-function door control (Figure 3). This sets the UP (open) limit and begins closing the door.

**NOTE: Excessive movement of the opener will cause premature wear. See Troubleshooting section.**

4. Immediately when the door begins to move down, press and release either the black or orange button. This will stop the door.
5. **Setting the DOWN position:** Push and hold the orange button until the door reaches the desired DOWN (closed) position (Figure 4).
6. Once the door is closed, check for proper pressure on the door (you should be able to manually push the door down 2mm). If there appears to be too much pressure on the door, you may toggle the door back and forth using the black and orange buttons to reach the desired position.
7. Push the transmitter, wireless wall button or the multi-function door control (Figure 3). This sets the DOWN (close) limit and should bring the door to the open position.

- If the opener is not stopping exactly where you would like it, repeat steps 1 through 7 and program the limits again.
- When the unit stops in both the desired up (open) and down (close) positions, proceed to *Adjustment Step 2, Setting the Force*.

## **⚠ WARNING**

Without a properly installed safety reversal system, persons (particularly children) could be **SERIOUSLY INJURED** or **KILLED** by a closing door.

- **NEVER** learn forces or limits when door is binding or sticking. Repair door first.
- Incorrect adjustment of the door travel limits will interfere with proper operation of safety reversal system.
- After **ANY** adjustments are made, the safety reversal system **MUST** be tested. Door **MUST** reverse on contact with 40mm high (1 1/2") object on floor.

## **CAUTION**

To prevent damage to vehicles, be sure fully open door provides adequate clearance.

**Figure 2**

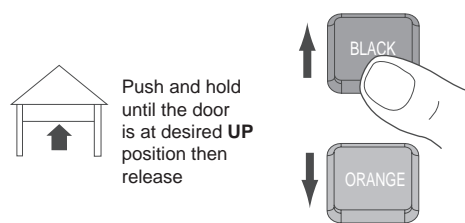

**Figure 3**

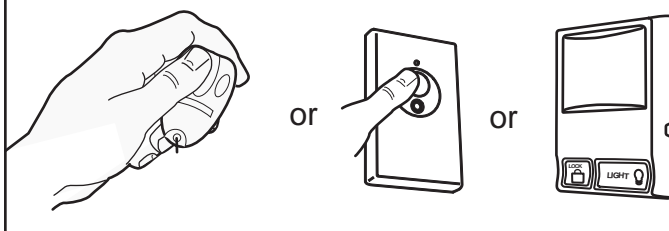

**Figure 4**

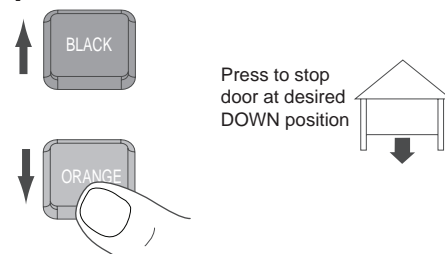

## ADJUSTMENT STEP 2

### SETTING THE FORCE

The force setting button is located on the front panel. The force setting measures the amount of force required to open and close the door.

1. Locate the orange button on the unit (Figure 1).
2. Push the orange button twice to enter unit into Force Adjustment Mode (Figure 2). The LED (Indicator Light) will flash quickly.
3. Push the transmitter, wireless wall button or multi-function door control (Figure 3). The door will travel to the DOWN (close) position. Push the transmitter, wireless wall button or multi-function door control again, the door will travel to the UP (open) position.

The LED (Indicator Light) will stop flashing when the force has been learnt.

The unit has learnt the forces required to open and close your door.

The door must travel through a complete cycle, UP and DOWN, in order for the force to be set properly. If the unit cannot open and close your door fully, inspect your door to ensure that it is balanced properly and is not sticking or binding. See page 4, "Preparing your door."

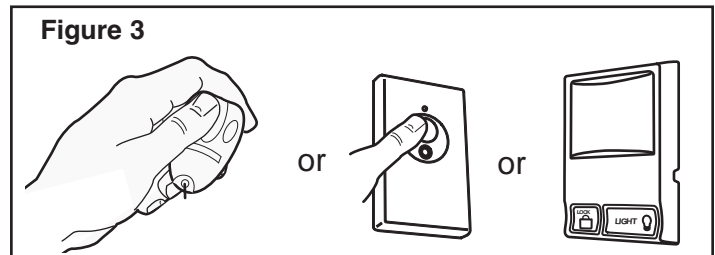
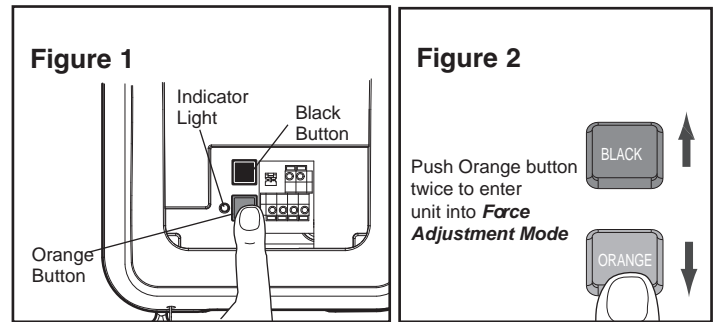

### **⚠ WARNING**

Without a properly installed safety reversal system, persons (particularly children) could be **SERIOUSLY INJURED** or **KILLED** by a closing the door.

- NEVER learn forces or limits when door is binding or sticking. Repair door first
- Too much force on door will interfere with proper operation of safety reversal system.
- After ANY adjustments are made, the safety reversal system **MUST** be tested. Door **MUST** reverse on contact with 40mm (1 1/2") high obstacle on floor.

---

## ADJUSTMENT STEP 3

### TEST THE SAFETY REVERSAL SYSTEM

#### TEST

- With the door fully open, place a 40mm (1 1/2") obstacle on the floor, centered under the door.
- Operate the door in the down direction. The door **must** reverse on contact with the obstruction. Upon successful safety reversal test proceed to "Adjustment Step 4".

#### ADJUST

- If the door stops on the obstacle, it is not traveling far enough in the down direction. Complete Adjustment Steps 1 and 2 Programming the Limits and Forces.
- Repeat the test.
- When the door reverses on the 40mm (1 1/2") obstacle, remove the obstacle and run the opener through 3 or 4 complete travel cycles to test adjustment.
- If the unit continues to fail the Safety Reverse Test, call for a trained door systems technician.

#### IMPORTANT SAFETY CHECK:

Test the Safety Reverse System after:

- Each adjustment of limits, or force controls.
- Any repair to or adjustment of the door (including springs and hardware).
- Any repair to or buckling of the floor.
- Any repair to or adjustment of the opener.

---

## ADJUSTMENT STEP 4

### TEST THE PROTECTOR SYSTEM™

- Press the transmitter push button to open the door.
- Place the opener carton in the path of the door.
- Press the transmitter push button to close the door. The door will not move and the LED indicator light will flash twice.

The door opener will not close from a transmitter if the indicator light in either sensor is flashing or off (alerting you to the fact that the sensor is misaligned or obstructed).

**If the opener closes the door when the safety reversing sensor is obstructed, do not operate the door. Call for a trained door systems technician.**

## ⚠ WARNING

Without a properly installed safety reversal system, persons (particularly children) could be **SERIOUSLY INJURED** or **KILLED** by a closing the door.

- Safety reversal system **MUST** be tested every month.
- If one control (force or travel limits) is adjusted, the other control may also need adjustment.
- After **ANY** adjustments are made, the safety reversal system **MUST** be tested. Door **MUST** reverse on contact with 40mm (1 1/2") high obstacle on the floor.

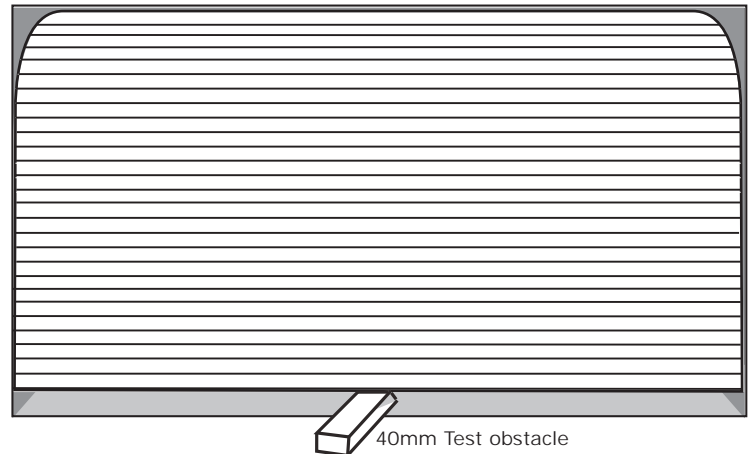



## ADJUSTMENT STEP 5 TO OPEN THE DOOR MANUALLY

The door should be fully closed if possible. Pull down on the emergency release handle until a click noise is heard from the unit and lift the door manually. To reconnect the door to the opener, pull down the emergency release handle straight down a second time until a click noise is heard from the unit. The door will reconnect on the next UP or DOWN operation.

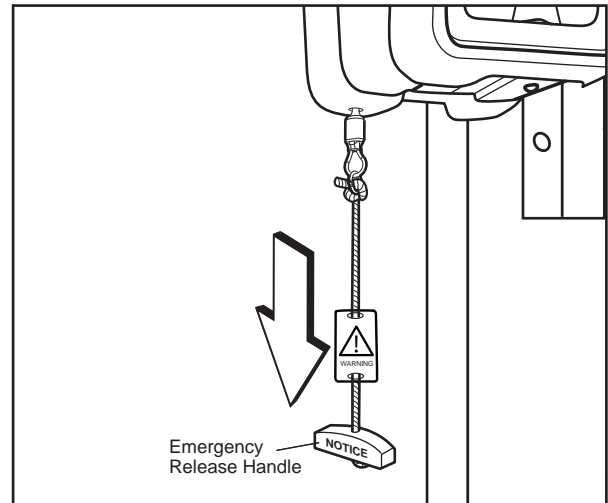

## OPERATION

### IMPORTANT SAFETY INSTRUCTIONS

#### **WARNING**

#### To reduce the risk of SEVERE INJURY or DEATH:

1. READ AND FOLLOW ALL WARNINGS AND INSTRUCTIONS.
2. ALWAYS keep transmitters out of reach of children. NEVER permit children to operate or play with the wireless wall button, multi-function door control or transmitters.
3. ONLY activate the door when it can be seen clearly, it is properly adjusted and there are no obstructions to door travel.
4. ALWAYS keep the door in sight until completely closed. NO ONE SHOULD CROSS THE PATH OF THE MOVING DOOR.
5. NO ONE SHOULD GO UNDER A STOPPED, PARTIALLY OPENED DOOR.
6. If possible, use emergency release handle to disengage door ONLY when the door is CLOSED. Weak or broken springs or unbalanced door could result in an open door falling rapidly and/or unexpectedly.
7. NEVER use emergency release handle unless the doorway is clear of persons and obstructions.
8. After ANY adjustments are made, the safety reversal system MUST be tested.
9. Safety reversal system MUST be tested every month. The door MUST reverse on contact with 40mm (1 1/2") high obstacle on the floor.
10. ALWAYS KEEP THE DOOR PROPERLY BALANCED (see page 4). An improperly balanced door may not reverse when required and could result in SEVERE INJURY or DEATH.
11. ALL repairs to cables, spring assemblies and other hardware, ALL of which are under EXTREME tension, MUST be made by a trained door systems technician.
12. ALWAYS disconnect electric power to the door opener BEFORE making ANY repairs or removing covers.
13. Permanently fix the Emergency release instruction label adjacent to the release handle.
14. **KEEP THESE INSTRUCTIONS.**

### EMERGENCY DOOR RELEASE

#### **WARNING**

To prevent possible SERIOUS INJURY or DEATH from a falling door:

- If possible, use emergency release handle to disengage door ONLY when door is CLOSED. Weak or broken springs or unbalanced door could result in an open door falling rapidly and/or unexpectedly.
- NEVER use emergency release handle unless the doorway is clear of persons and obstructions.

# WIRELESS PROGRAMMING

Your door opener has already been programmed at the factory to operate with your hand-held transmitter. The door will open and close when you press the large centre button.

Below are instructions for programming your opener to operate with additional Security\* transmitters.

## TO ADD OR REPROGRAM A HAND-HELD TRANSMITTER

### USING THE "LEARN" BUTTON

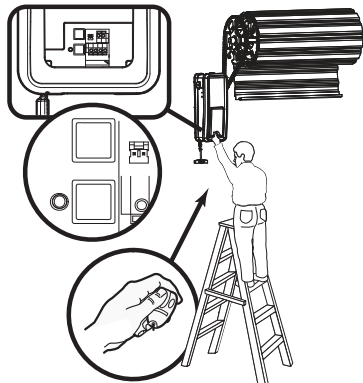

1. Press and hold button on the transmitter you wish to program to the opener.

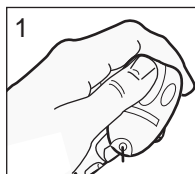

2. The orange LED (indicator light) will flash to indicate it is receiving signal from the transmitter.

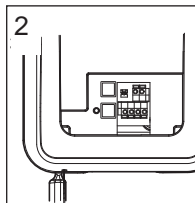

3. Press & release the orange "learn" button on the opener. Release the button on the transmitter. The code has been learnt.

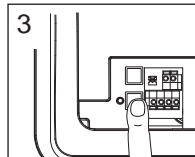

### WIRELESS PROGRAMMING A FINGERPRINT ENTRY SYSTEM C379 (OPTIONAL) (NOT SUPPLIED)

Full instructions are available with this accessory. Once you have enrolled your users into the C379 you can program the unit into your opener.

#### Using the orange "LEARN" button:

1. Press and release the orange "learn" button (1) on opener. The learn indicator light will glow steadily for 30 seconds.
2. Within 30 seconds slide the cover of the C379 up as illustrated (A). Swipe your finger on the reader head at a steady speed (B) until the LED turns on (C).
3. When the LED indicator light turns off it has learnt the code. Ensure there are no obstructions in the path of the door, then press the send button (D) to test the door.

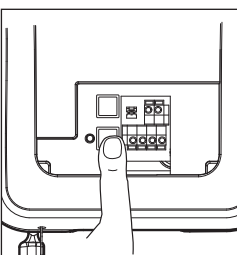

### TO ERASE ALL CODES FROM OPENER MEMORY

To deactivate any unwanted transmitter, first erase all codes: Press and hold the orange learn button on opener until the learn indicator LED goes out (approximately 6-9 seconds).

**Note: All previous codes are now erased.**  
Reprogram each transmitter or keyless entry you wish to use.

### 3-BUTTON TRANSMITTERS

If provided with your garage door opener, the large button is factory programmed to operate it. Additional buttons on any 3-button transmitter or mini-transmitter can be programmed to operate other Merlin Professional garage door openers or gate openers.

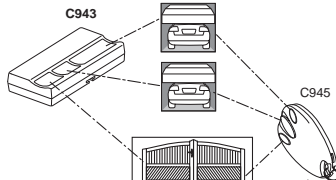

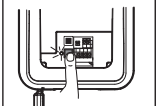

Press orange LEARN Button

LED will start flashing

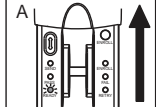

Slide the cover plate up (A)

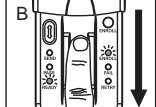

Swipe finger at a steady speed (B)

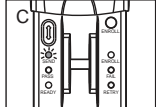

Yellow LED will indicate successful swipe (C)

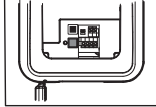

LED indicator light will turn off

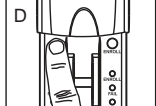

Test reader by pressing the send button (D)

# WIRELESS PROGRAMMING

## TO ADD, REPROGRAM OR CHANGE A KEYLESS ENTRY PIN

### USING THE “LEARN” BUTTON

1. Press and release the orange “learn” button on opener. The learn indicator LED will glow steadily for 30 seconds.
2. Within 30 seconds, enter a four digit personal identification number (PIN) of your choice on the keypad. Then press and hold the ENTER button.
3. Release the button when the opener LED turns off.

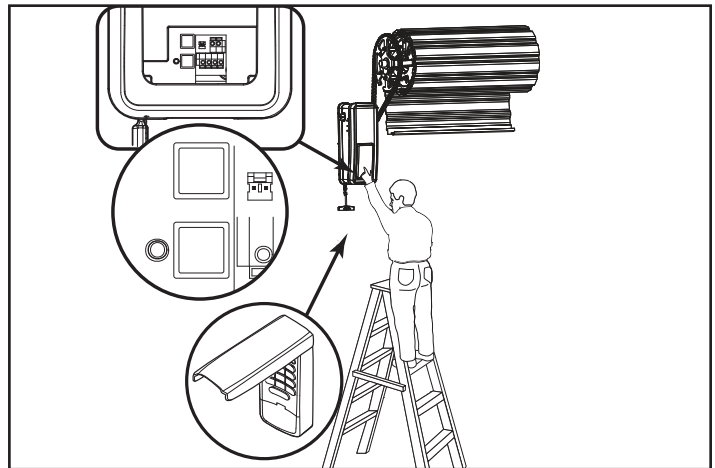
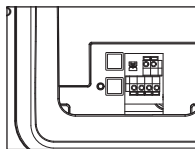
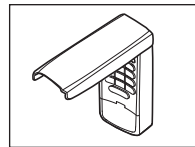
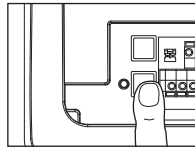

### To change an existing, known PIN

If the existing PIN is known.

1. Press the four buttons for the present PIN, then press and hold the # button.  
The LED on the opener will turn on.
2. Press the new 4-digit PIN you have chosen, then press Enter.

The indicator LED will turn off. Code has been learnt.

Test by pressing the new PIN, then press Enter. The door should move.

### To set a temporary PIN

You may authorise access to visitors or service people with a temporary 4-digit PIN. After a programmed number of hours or number of accesses, this temporary PIN expires and will no longer open the door. It can be used to close the door even after it has expired. To set a temporary PIN:

1. Press the four buttons for your personal entry PIN (not the last temporary PIN), then press and hold the \* (star button).
2. Press the temporary 4-digit PIN you have chosen, then press Enter.
3. To set the number of **hours** this temporary PIN will work, press the number of hours (up to 255), then press \* (star button).

OR

3. To set the number of **times** this temporary PIN will open door, press the number of times (up to 255), then press # (hash button).

The indicator light will turn off when the temporary PIN has been learnt.

Test by pressing the four buttons for the temporary PIN, then press Enter. The door should move. If the temporary PIN was set to a certain number of openings, remember that the test has used up one opening. To clear the temporary password, repeat steps 1-3, setting the number of hours or times to 0 in step 3.

**One Button Close:** Opener can be closed by pressing only the ENTER button if the one button close feature has been activated. This feature has been activated at the factory. To activate or deactivate this feature press and hold buttons 1 and 9 for 10 seconds. The keypad will flash twice when the one button close is active. The keypad will flash four times when one button close is deactivated.

### THE TRANSMITTER BATTERY

#### ⚠ WARNING

To prevent possible SERIOUS INJURY or DEATH:

- NEVER allow small children near batteries.
- If battery is swallowed, immediately notify doctor.

#### ⚠ WARNING

To reduce risk of fire, explosion or chemical burn:

- Replace with ONLY CR2032 batteries.
- Do NOT recharge, disassemble, heat above 75°C or incinerate.

To replace battery, use a screwdriver blade to pry open the case as shown. Insert battery positive side up.

Dispose of old battery properly.

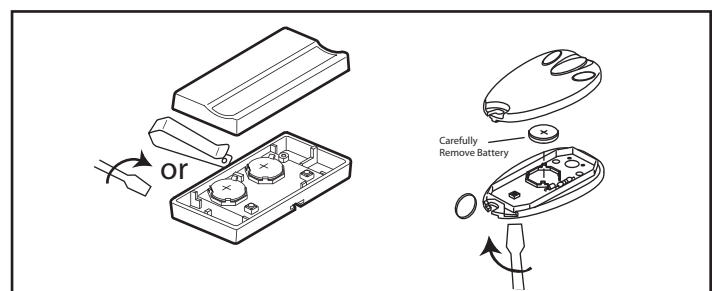

# REPAIR PARTS

## Installation Parts

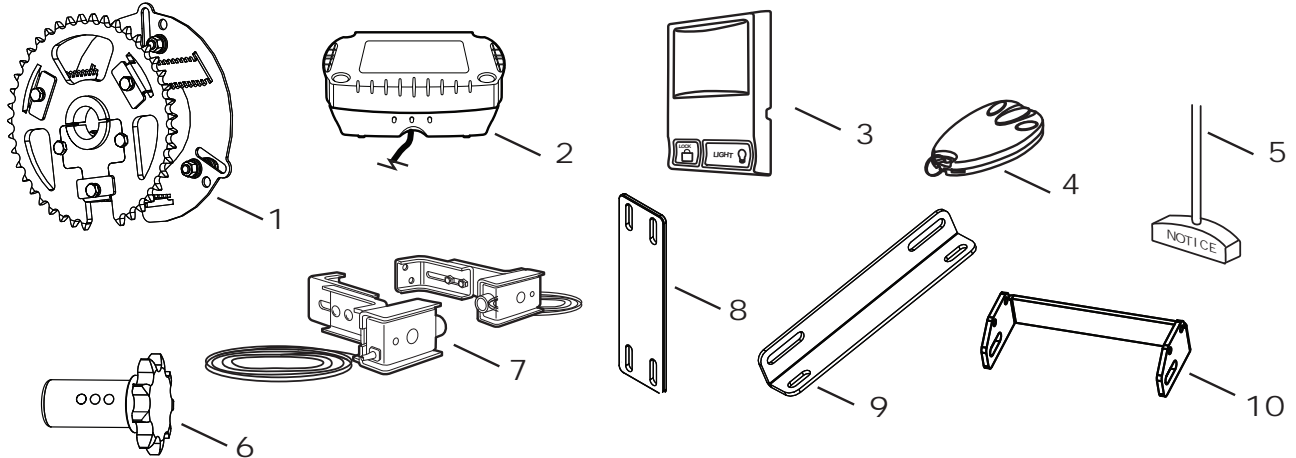

KEY NO.	PART NO.	DESCRIPTION			
1	EFS57	Easy-Fit sprocket kit (Pat. pend)	6	STUB1	Stub sprocket
2	CM475	Evercharge™ standby power unit	7	C77	The Protector System™ (IR Beams)
3	845AML	Multi-function door control	8	EXTP1	Extension plate
4	C945	3 Channel mini transmitter	9	ANGB1	Angle bracket
5	041A4582	Emergency release rope & handle assembly	10	MBK1	Mounting bracket

## Opener Assembly Parts

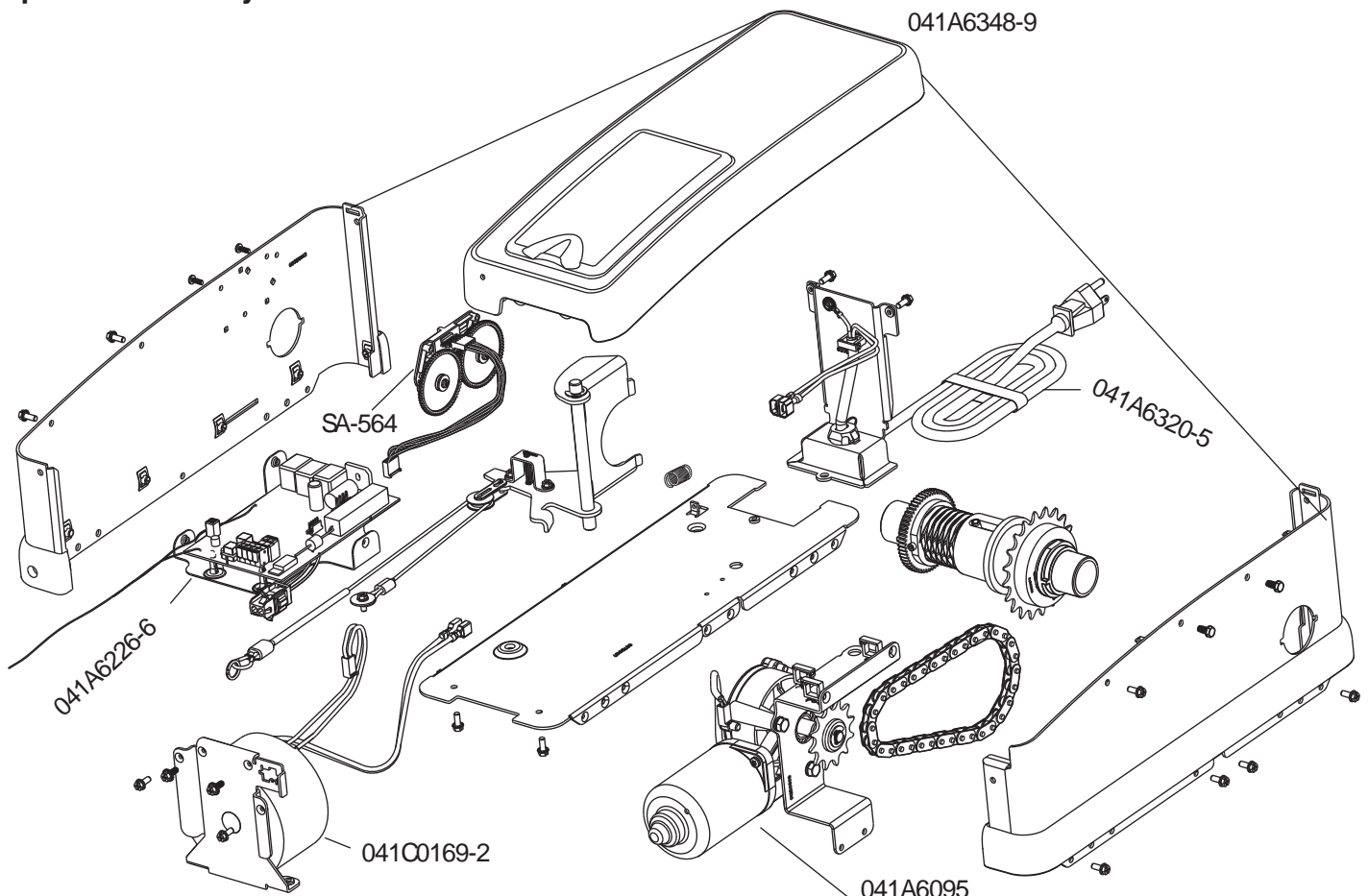

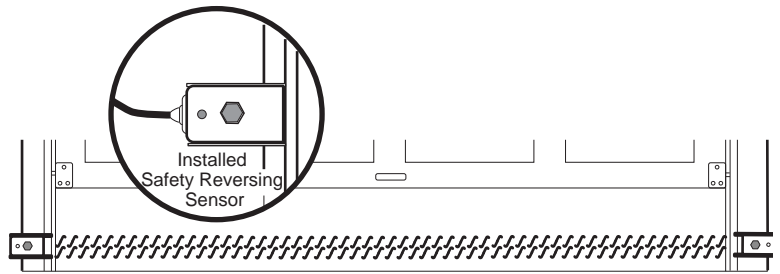
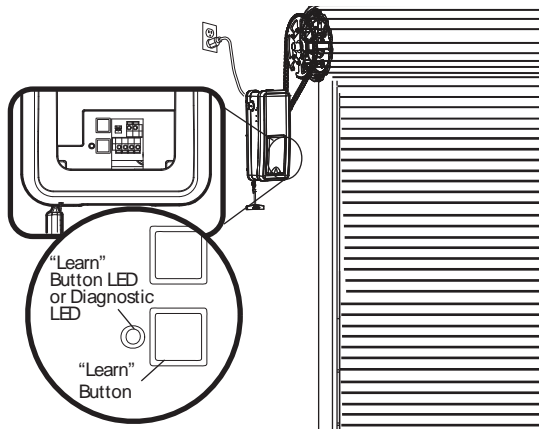

Your door opener is programmed with self-diagnostic capabilities. The "Learn" button/diagnostic LED will flash a number of times then pause signifying it has found a potential issue. Consult Diagnostic Chart below.

## DIAGNOSTIC CHART

### 1 FLASH

Safety reversing sensors wire open (broken or disconnected).

OR

### 2 FLASHES

Safety reversing sensors wire shorted or black/white wire reversed.

### 3 FLASHES

Multi-function door control or wire shorted.

### 4 FLASHES

Safety reversing sensors slightly misaligned (dim or flashing LED).

### 5 FLASHES

Possible RPM sensor failure. Unplug to reset.

### 9 FLASHES

Reversal indicator

### 10 FLASHES

Reversal indicator

- **Symptom: One or both of the Indicator lights on the safety reversing sensors do not glow steady.**
  - Inspect sensor wires for a short (staple in wire), correct wiring polarity (black/white wires reversed), broken or disconnected wires, replace/attach as needed.
  - Disconnect all wires from opener.
  - Remove sensors from brackets and shorten sensor wires to 30-60mm (1-2") from back each of sensor.
  - Reattach sending eye to opener using shortened wires. If sending eye indicator light glows steadily, attach the receiving eye.
  - Align sensors, if the indicator lights glow replace the wires for the sensors. If the sensor indicator lights do not light, replace the safety reversing sensors.
- **Symptom: LED is not lit on multi-function door control.**
  - Inspect Multi-Function Door Control/wires for a short (staple in wire), replace as needed.
  - Disconnect wires at multi-function door control, touch wires together. If opener activates, replace multi-function door control.
  - If opener does not activate, disconnect multi-function door control wires from opener. Momentarily short across red and white terminals with jumper wire. If opener activates, replace multi-function door control wires.
- **Symptom: Sending indicator light glows steadily, receiving indicator light is dim or flashing.**
  - Realign receiving eye sensor, clean lens and secure brackets.
  - Verify door track is firmly secured to wall and does not move.
- **Symptom: The RPM Sensor = Short travel 150-200mm (6-8").**
  - Unplug unit to reset. Try to operate opener, check diagnostic code.
  - If it is still flashing 5 times and opener moves 150-200mm (6-8"), the unit's APE (Absolute Positioning Encoder) may need to be replaced, for details contact your Chamberlain reseller.
- **Symptom: Door reverses while closing.**
  - Check for possible door obstructions and remove.
  - Ensure factory installed resistor is installed correctly across the green terminals.
- **Symptom: Door won't close**
  - Check for possible door obstructions and remove.
  - Check beam alignment.

---

## TROUBLESHOOTING

### **1. The opener doesn't operate from either the multi-function door control, wireless wall button or the transmitter:**

- Does the opener have electric power? Plug a lamp into the outlet. If it doesn't light, check the fuse box or the circuit breaker. (Some outlets are controlled by a wall switch.)
- Have you disabled all door locks? Review installation instruction warnings on page 6.
- Is there a build-up of ice or snow under the door? The door may be frozen to the ground. Remove any restriction.
- The door spring may be broken. Have it replaced (see page 4 for reference).

### **2. Opener operates from the transmitter, but not from the Optional Wireless Wall Button:**

- Check the LED on the Wireless Wall Button to ensure the LED turns on when button is pushed. If the LED is weak or not on Change the batteries. (Remove cover and replace with CR2032 batteries).
- If the LED turns on and is strong check to ensure the unit is programmed into the opener (Wireless programming).

### **3. The door operates from the multi-function door control but not from the transmitter:**

- Is the multi-function door control actuator button flashing? If so, lock mode is engaged. Make sure it is off by pressing the Lock button for two seconds.
- Program the opener to match the transmitter code. (Refer to instructions on the opener panel.) Repeat with all transmitters.

### **4. The transmitter has short range:**

- Change the location of the transmitter in your car.
- Check to be sure the antenna on the side or back panel of opener extends fully downward.
- Some installations may have shorter range due to a metal door, foil backed insulation, or metal siding.

### **5. The door opens and closes by itself:**

- Be sure that all transmitter push buttons are off.
- Remove the bell wire from the multi-function door control terminals and operate from the transmitter only. If this solves the problem, the multi-function door control is faulty (replace), or there is an intermittent short on the wire between the control console and the opener.
- Clear memory and re-program all transmitters.

### **6. The door doesn't open completely:**

- Check powered door lock.
- Is something obstructing the door? Is it out of balance, or are the springs broken? Remove the obstruction or repair the door.

### **7. The door opens but won't close:**

- If the opener LED is flashing, check the safety reversing sensor. See *Installation Step 8*.
- If the opener LED is not flashing and it is a new installation. See *Adjustment Step 2*. For an existing installation, see below.

*Repeat the safety reverse test after the adjustment is complete.*

### **8. The door reverses for no apparent reason and opener LED doesn't flash:**

- Is something obstructing the door? Pull the emergency release handle. Operate the door manually. If it is unbalanced or binding, call a trained door systems technician.
- Clear any ice or snow from the floor area where the door closes.
- Review *Adjustment Step 2*.

*Repeat safety reverse test after adjustments.*

### **9. The door reverses for no apparent reason and opener LED flashes for 5 seconds after reversing:**

- Check the safety reversing sensor. Remove any obstruction or align the receiving eye. See *Installation Step 8*.

### **10. The opener strains to operate door:**

- The door may be out of balance or the springs may be broken. **Close the door** and use the emergency release handle to disconnect the door. Open and close the door manually. A properly balanced door will stay in any point of travel while being supported entirely by its springs. If it does not, disconnect the opener and call a trained door systems technician.

### **11. The opener motor hums briefly, then won't work:**

- The door springs may be broken. See above.
- If the problem occurs on the first operation of the opener, door may be locked. Disable the powered door lock.

### **12. The opener won't operate due to power failure:**

- Manually open the powered door lock.
- Use the emergency release handle to disconnect the door. The door can be opened and closed manually. When power is restored, pull manual release a second time.
- If an EverCharge Unit is connected, the opener should be able to operate up to 20 times without power.

### **13. Door loses limits.**

- Reprogram limits, see adjustment step 1.

## OPERATION OF THE OPENER

Your Merlin® Security+ opener and hand-held transmitter have been factory-set to a matching code which changes with each use, randomly accessing over 100 billion new codes. Your opener will operate with up to 64 Merlin® Security+ transmitters and one Keyless Entry System. If you purchase a new transmitter, or if you wish to deactivate any transmitter, follow the instructions in the *Programming* section.

### **Activate your opener with any of the following:**

- *The hand-held transmitter:* Hold top middle button down until the door starts to move.
- *The Keyless Entry:* Must be programmed before use. See *Programming*.
- *Multi-Function Door Control*

### **When the opener is activated (with the safety reversing sensor correctly installed and aligned)**

1. If open, the door will close. If closed, it will open.
2. If closing, the door will reverse.
3. If opening, the door will stop.
4. If the door has been stopped in a partially open position, it will close.
5. If obstructed while closing, the door will stop and reverse. The LED indicator light will flash.
6. If obstructed while opening, the door will stop.
7. If fully open, the door will not close when the beam is broken. The sensor has no effect in the opening cycle.

If the sensor is not installed, or is misaligned, the door won't close from a hand-held transmitter or wireless wall button. However, you can close the door with the multi-function door control, the Outside Keylock, or Keyless Entry, *if you activate them until down travel is complete*. If you release them too soon, the door will reverse.

### Using your C945 3ch Mini-Transmitter

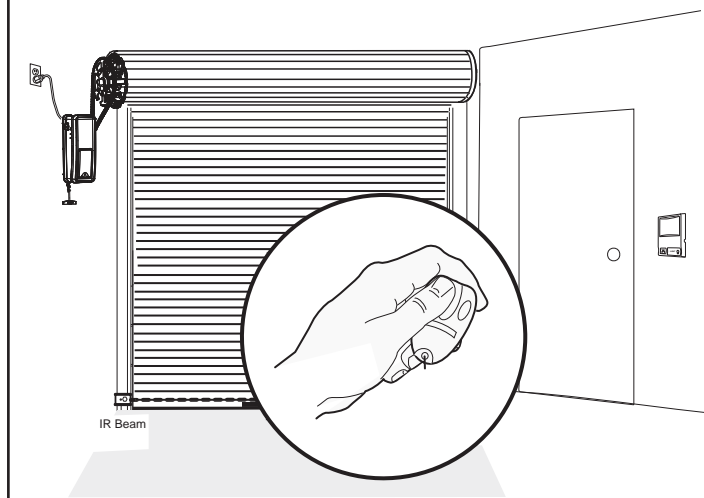

### Using your Multi-Function Door Control

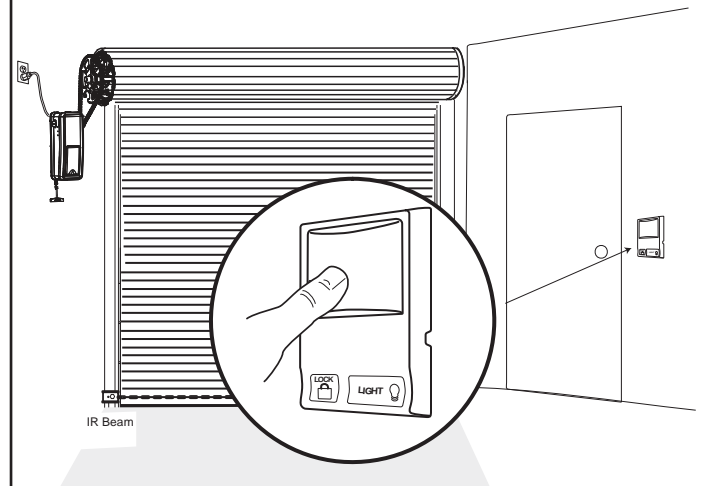

## CARE OF YOUR OPENER

### MAINTENANCE SCHEDULE

#### **Once a Month**

- Manually operate door. If it is unbalanced or binding, call a trained door systems technician.
- Check to be sure door opens & closes fully. Adjust limits and/or force if necessary (see Adjustment Steps 1 and 2).
- Repeat the safety reverse test. Make any necessary adjustments (see Adjustment Step 3).

#### **Once a Year**

- Clean the door tracks. The opener does not require additional lubrication. Do not grease the door tracks.

## CHAMBERLAIN LIMITED WARRANTY

Merlin MJ3800R

Garage Door Opener

**Chamberlain Australia Pty Limited / Chamberlain New Zealand Limited (Seller) warrants to the original purchaser of the Merlin MJ3800R Garage Door Opener (Unit) that it is free from defects in material and/or workmanship for a period of 2 YEARS from the date of first purchase from the Seller. The DC motor (only) has a 5 year warranty from the date of first purchase from the Seller when installed on a domestic door.**

Please retain your proof-of-purchase in the unlikely event you require warranty service.

If, during the limited warranty period, the Unit fails due to defects in materials or workmanship Chamberlain will, provided the defective part or Unit is returned freight and insurance prepaid and well packaged to the nearest Chamberlain office or authorised installer, undertake to repair or, at its option, replace any defective part or Unit and return it to the Buyer at no cost. Repairs and replacement parts are warranted for the remaining portion of the original warranty period.

Limited warranty on opener

Chamberlain will furnish a replacement opener free of charge, if it is found to be defective. Labour costs may apply. Where the Unit has been installed by an authorised installer, Chamberlain will furnish replacement parts free of charge through the authorised installer. A service fee for on-site service may apply.

In-warranty service

During the warranty period, if the product appears as though it may be defective, call our toll free service before removal of the Unit. A Chamberlain technician will diagnose the problem and promptly supply you with the parts for "do-it-yourself" repairs, or provide you with shipping instructions for a factory repair or replacement. If an authorised installer installed your Unit you must call them for prompt on-site service.

If our service centre determines that a warranty claim has been made in respect of a failure or defect arising out of any exclusion detailed below, we may charge you a fee to repair and/or return the Unit to you.

Exclusions

This warranty does not cover any failure of the Unit due to:

1. non-compliance with the instructions regarding installation, operation, maintenance and testing of the Unit or of any product with which the Unit is used.
2. any attempt to repair, dismantle, reinstall or move the Product to another location once the Product is installed by any person other than an authorised installer.
3. tampering, neglect, abuse, wear and tear, accident, electrical storm, excessive use or conditions other than normal domestic use.

This warranty does not cover any problems with, or relating to, the garage door or garage door hardware, including but not limited to the door springs, door rollers, door alignment or hinges, any problems caused by electrical faults, replacement of batteries or light bulbs or labour charges for reinstalling a repaired or replaced Units.

D-M-RDO/003 (v. 013061)

## Liability – Australia only

Under no circumstances shall the Seller be liable for consequential, incidental or special damages arising in connection with the use, or inability to use, the Unit. In no event shall the Seller's liability for damages or injury arising from breach of law or contract or for negligence, exceed the cost of repairing or replacing the Unit or refunding the purchase price of the Unit.

Under Division 2 Part V of the Trade Practices Act, 1974, certain warranties and conditions (Implied Terms) are implied into contracts for the supply of goods or services if the goods or services are of a kind ordinarily acquired for personal, domestic or household use or consumption. Liability for breach of those Implied Terms cannot be excluded or limited and the limitations and exclusions above do not apply to the Implied Terms.

Except for the Implied Terms and the warranties set out above, the Seller excludes all warranties and conditions implied by statute, at law, in fact or otherwise.

## Liability – New Zealand only

Except as set out in the Fair Trading Act 1986 and the Consumer Guarantees Act 1993:

(a) all other guarantees, warranties and representations in relation to the Unit or its supply are excluded to the extent that the Seller can lawfully exclude them; and

(b) under no circumstances shall the Seller be liable for consequential, incidental or special damages arising in connection with the use, or inability to use, the Unit, other than those which were reasonably foreseeable as liable to result from the failure.

**NOTE: We request that you attach your sales docket or invoice to this manual to enable you to establish the date of purchase in the unlikely event of a service call being made. Chamberlain reserves the right to change the design and specification without prior notification. Some features or accessories may not be available in certain markets or areas. Please check with your distributor.**

## CONTACT DETAILS:

**Chamberlain service centres:**

**Australia**

**Phone toll free 1800 638 234**

**Fax toll free 1800 888 121**

**New Zealand**

**Auckland phone 09 477 2823**

**Phone toll free 0800 653 667**

**Fax toll free 0800 653 663**

**[www.chamberlainanz.com](http://www.chamberlainanz.com)**

™ Trademark of The Chamberlain Group, Inc.

® Registered Trademark of The Chamberlain Group, Inc.

© 2010, The Chamberlain Group Inc.