

CHAMBERLAIN®

GRIFCO®

eDrive™

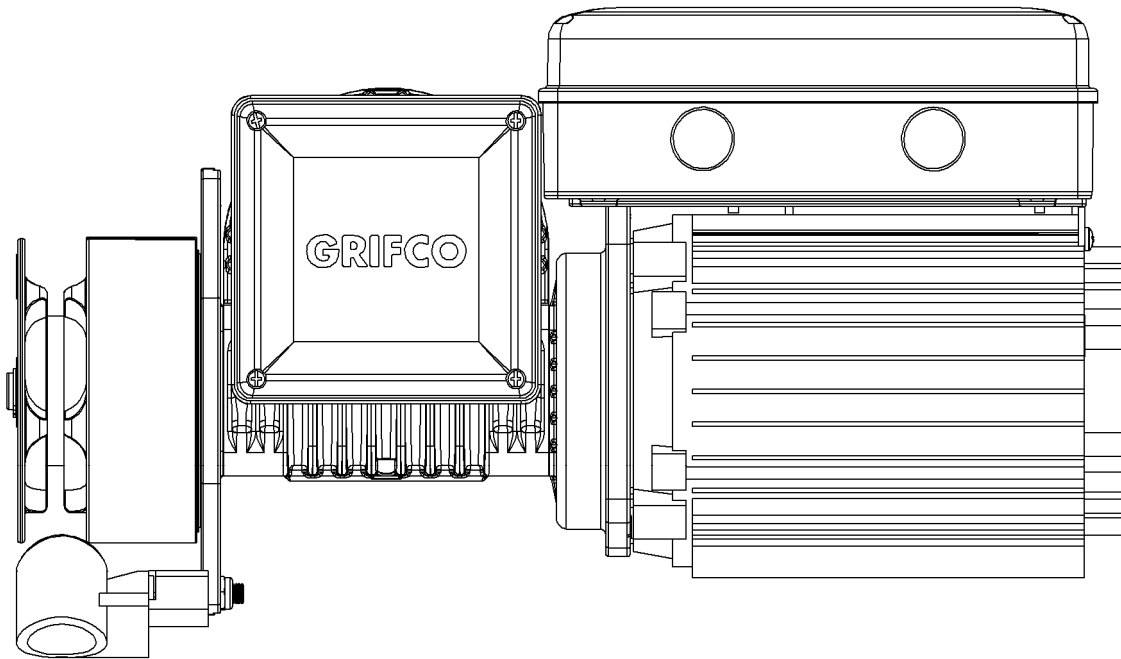

installation and users
manual for eDrive™
commercial door opener

Chamberlain Australia Pty Ltd
PO Box 1446, Lane Cove
NSW 1595, Australia
Phone toll free 1800 638 234

Chamberlain New Zealand Ltd
PO Box 100-221
North Shore 0745, New Zealand
Phone toll free 0800 653 667

www.chamberlainnz.com

Safety symbol and signal word review

This commercial door opener has been designed and tested to offer safe service provided it is installed, operated, maintained and tested in strict accordance with the instructions and warnings contained in this manual.



WARNING

Mechanical



WARNING

Electrical

CAUTION

When you see these Safety Symbols and Signal Words on the following pages, they will alert you to the possibility of serious injury or death if you do not comply with the warnings that accompany them. The hazard may come from something mechanical or from electric shock.

When you see this Signal Word on the following pages, it will alert you to the possibility of damage to your commercial door and/or the commercial door opener if you do not comply with the cautionary statements that accompany it.

THESE ARE IMPORTANT SAFETY INSTRUCTIONS. FOLLOW ALL INSTRUCTIONS SINCE INCORRECT INSTALLATION CAN LEAD TO SEVERE INJURY OR DEATH



Keep commercial door balanced. Sticking or binding doors must be repaired. Commercial doors, door springs, pulleys, brackets and their hardware are under extreme tension and can cause serious personal injury. **Do not attempt to loosen, move or adjust them.** Call for commercial door service.



Do not wear rings, watches or loose clothing while installing or servicing a commercial door opener.



To avoid serious personal injury from entanglement, **remove all ropes connected to the commercial door** before installing the door opener.



Installation and wiring must be in compliance with your local building and electrical codes. **Connect the power supply cord only to properly earthed mains.**



Moisture and water can destroy the electronic components. Make sure under all circumstances that water moisture or storage moisture cannot penetrate the electronics. The same applies for openings and cable entries.



After the installation a final test of the full function of the system and the full function of the safety devices must be done.



When operating a biased-off switch, make sure that other persons are kept away.



The opener can not be used with a driven part incorporating a wicket door (unless the opener can not be operated with the wicket door open).



Permanently fasten all supplied **labels** adjacent to the wall control as a convenient reference and reminder of safe operating procedures.



Disengage all existing commercial door locks to avoid damage to commercial door. Install the wall control (or any additional push buttons) **in a location where the commercial door is visible during operation**. **Do not allow children to operate push button(s) or remote control(s).** Serious personal injury from a closing commercial door may result from misuse of the opener.



Activate opener only when the door is in full view, free of obstructions and opener is properly adjusted. No one should enter or leave the building while the door is in motion.



An electrician must disconnect electric power to the commercial door opener before making repairs or removing covers.



The actuating member of a biased-off switch is to be located within direct sight of the door but away from moving parts. **Unless it is key operated,** it is to be installed at a minimum height of 1500mm and **not accessible to the public.**



Make sure that people who install, maintain or operate the door follow these instructions. Keep these instructions in a safe place so that you can refer to them quickly when you need to.



This appliance is not intended for use by persons (including children) with reduced physical, sensory or mental capabilities, or lack of experience and knowledge, unless they have been given supervision or instruction concerning use of the appliance by a person responsible for their safety. Children should be supervised to ensure that they do not play with the appliance.

TABLE OF CONTENTS

Safety rules	2	• Optional third limit	11
Introduction	3	Operation	12
Identifying your eDrive™	3	Door behaviour and obstruction detection inputs	12-14
Planning	4	• Setting door behaviour	13
Installation	5-7	• Installing obstruction detection devices	14
• Mounting the unit	5-6	• Additional switchgear / Accessories	14
• Installing hand chain	7	Main Control Board (MCB)	15
• Connecting power	8	Troubleshooting / status table	16
• Controller	9	Having a problem?	17
• Installing controller	9	Maintenance	18
• Self adhesive pouch	9	Accessories	19
Setup and adjustment	10	• IR Beam and Remote Control Kit	19
• Checking power	10	• Elite Expansion Board upgrade kit	19
• Door direction	10	Warranty	20
• Changing door direction	10		
• Setting limits	11		

INTRODUCTION

Congratulations on your purchase of the Grifco® eDrive™ Commercial Door Opener. The eDrive™ is a state-of-the-art opener using sophisticated digital electronics and robust mechanical gearing that provides a balance of user friendly operation and high level technology.

The new eDrive™ brings together the latest in electronic technology with an Absolute Position Encoder (APE), multiple monitored obstruction inputs and many other advanced features.

IDENTIFYING YOUR eDrive™

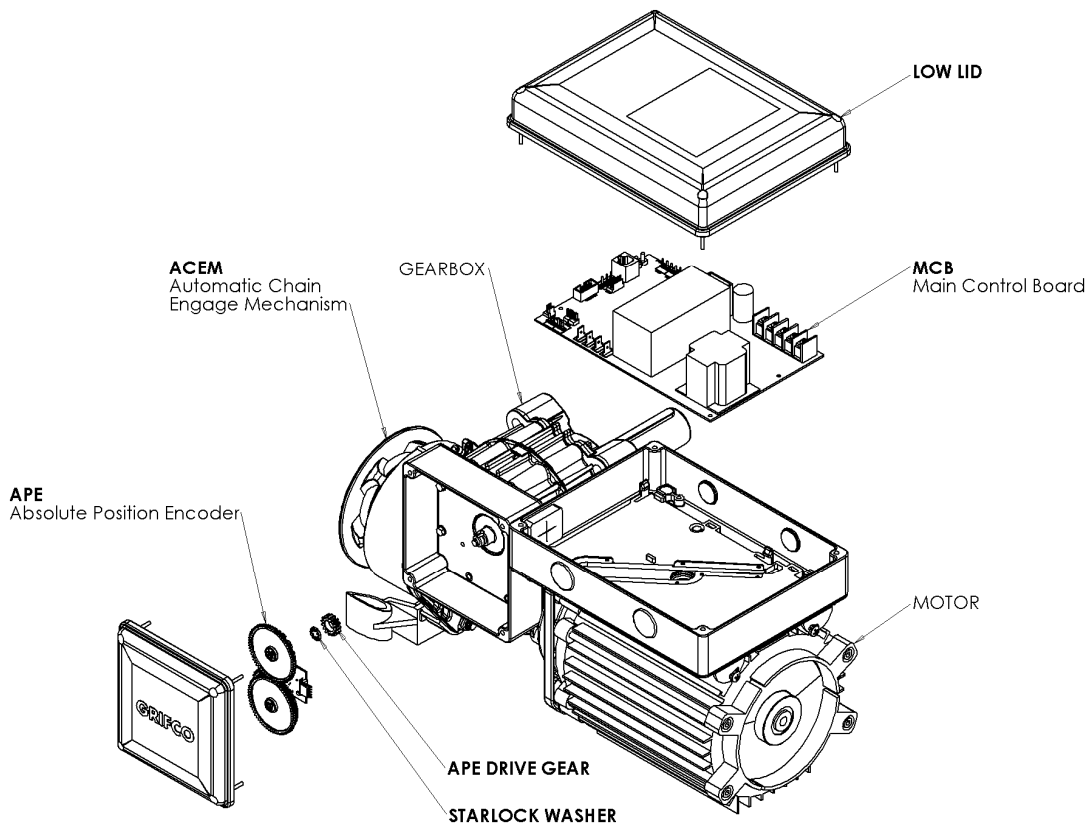

Appearance may vary with different motor, gearbox and controller types

- Your standard eDrive™ includes the opener, mounting bolts, and controller (containing controller cable and conduit entries)
- Some optional accessories may also be included such as a mounting plate, sprockets and chain

CAUTION

Please remove any locks fitted to the door before operation in order to prevent damage to the door.

WARNING

Make sure that people who install, maintain or operate the door follow these instructions. It is advised that the instruction be kept in a safe place so that you can refer to them quickly when you need to.

PLANNING

Identify the type and dimensions of your commercial rolling door. A check of the application is recommended to ensure suitability of the opener model to the door.

Opener Build	Rated Load (Nm)	Hp	Duty Rating (%)	Phase	Door size (m ²)*	kW	Amp	Max Door Mass (KG)**
ML4053	53	0.5	10	3	18	0.37	1.55	270
ML4103	140	1.0	10	3	36	0.75	2.3	540
MH4103	80	1.0	30	3	30	0.75	1.95	450
ML4153	190	1.5	10	3	50	1.1	2.55	890
ML4051	67	0.5	10	1	18	0.37	3.4	270
ML4102	85	1.0	10	1	36	0.75	6	480
MH4102	73	1.0	30	1	30	0.75	4.35	450

* Door size is stated as a guide only. Refer to "max door mass" to assess drive suitability.

** Maximum door mass is:

- before spring balancing. Door must be spring balanced.
- based on at least 4:1 sprocket ratio, and curtain load at 200mm diameter

If any conditions above are not met, some consideration should be given to increasing the sprocket ratio, or opener size. The opener should be installed on the most suitable side of the commercial door. Consider an In-Board Mounting Kit (P/N IBMK) if there is insufficient side room. Select the side that meets the requirements listed below.

- Must have minimum distance of 15mm between mounting plate and door drum sprocket (refer pg 5 image no. 1)
- Must have minimum distance of 10mm between APE housing and imposing structure (refer pg 6 image no. 4)
- Must have minimum overhead clearance of 150mm from the main control housing (refer pg 6 image no. 5)

Note: Before installing the opener, check that the commercial door is in good mechanical condition, correctly balanced and open and closes properly.

When using a Grifco eDrive™ on commercial doors of 'rigid' construction, consider that the limit position 're-find' movement requires a 1/4 turn of the output shaft downward at the closed position. Sufficient mechanical freedom must be provided at the closed position for this reason.

A clutch module is recommended for bi-fold doors and vertical-lift doors.



WARNING

The door guides must be fitted with mechanical stops that prevent the bottom rail from passing through in the opening direction. The opener should stall if driving into the mechanical stops.

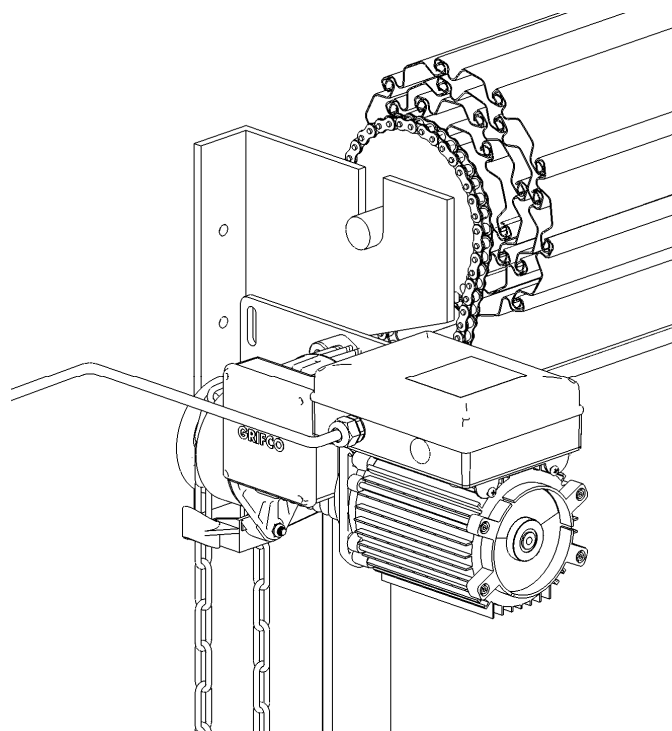

INSTALLATION SECTION

Mounting the unit

The eDrive™ is typically flag mounted below the door drum so that the opener shaft points toward the door opening and lies beneath the sprocket of the door drum. For mounting you will need to either secure the opener to the roller shutter head plate with prepared holes or slots, or use a mounting plate that will need fixing via a wall angle or similar existing structure.

Note: The eDrive™ is not designed to be upside down. The chain guide must not be repositioned.

It is strongly recommended a suitably rated lifting strap be used to raise the opener to a necessary height, shown right. A suitable lifting device should be connected to a secure support beam (or similar) above the door axle.

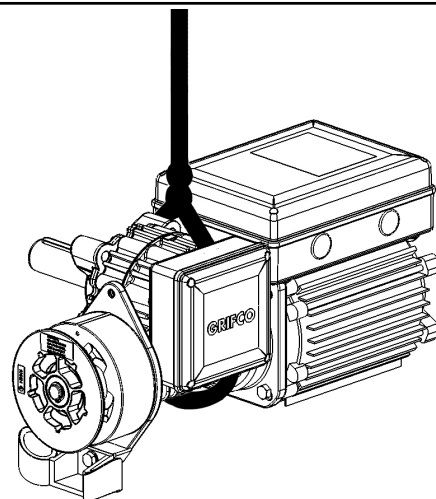

When assessing and selecting an appropriate mounting location, the following considerations should be made:

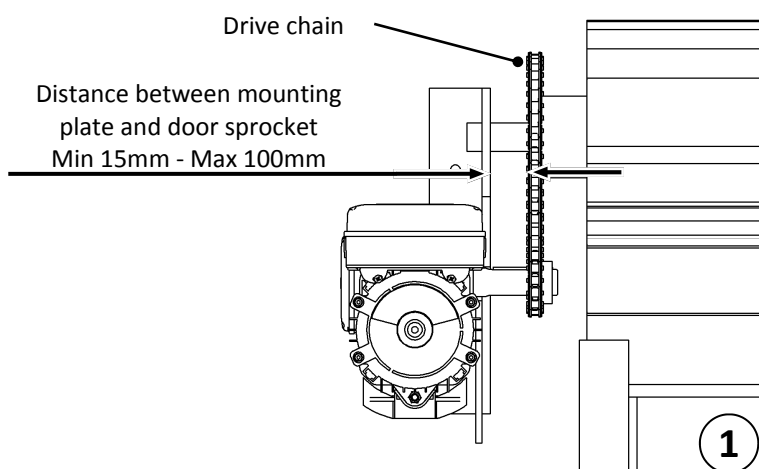

Alignment of door sprocket to output shaft of eDrive™ (see left)

Mounting plate slots allow the chain tension to be adjusted through vertical movement of the opener (see right)

Mounting plate slots

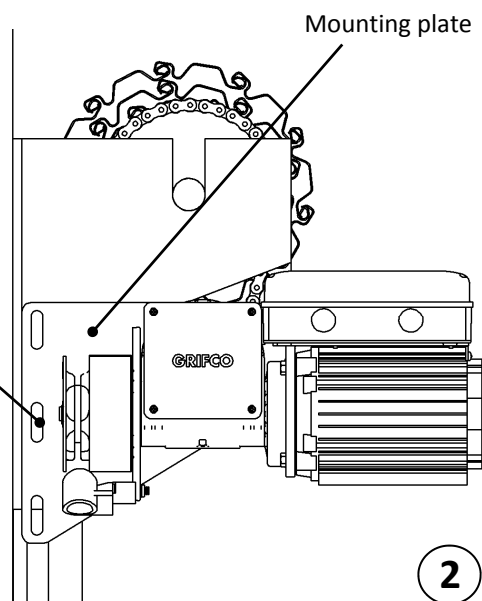

Clear path for manual chain to hang downward (refer pg 7 image no. 7 & 8)

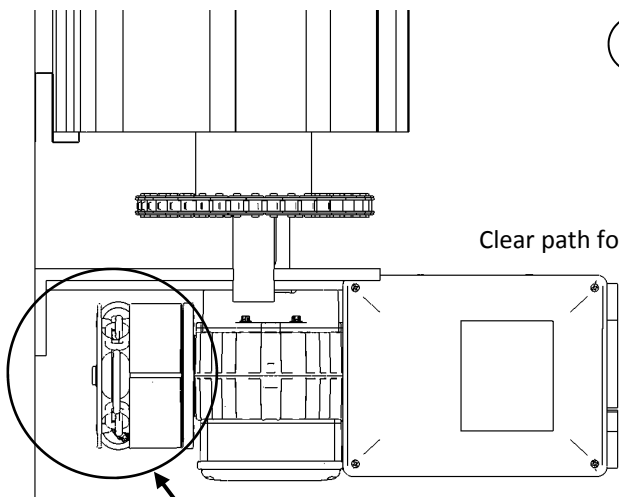

Room needed below for safe chain operation

Mounting the unit (continued)

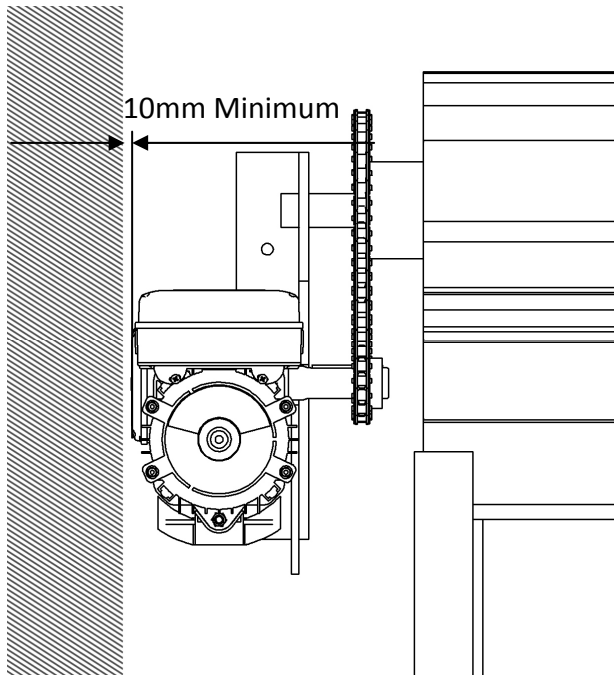

Side room to imposing structures (see left).

The eDrive™ APE housing is not a serviceable area and can be located within 10mm of an imposing structure without affecting installation. Where there is insufficient side room, consider using the opposite hand opener and mount inboard with a Grifco™ Inboard Mounting Kit, P/N IBMK.

Limited head room (see right).

The eDrive™ main control housing is a serviceable area and will need to be accessed by service personnel. Refer below for options on how to overcome problems in which sufficient head room is not available.

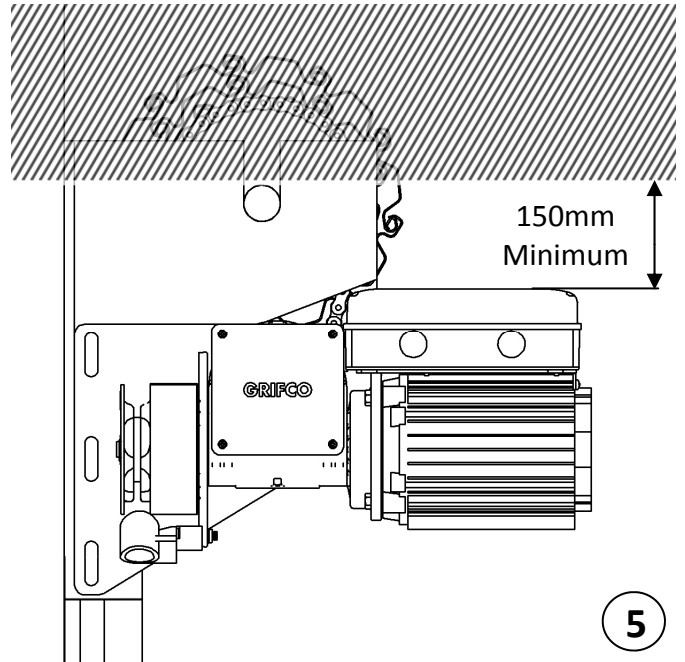

If there is insufficient head room above the eDrive™ opener to allow servicing then a Grifco™ Wall Mount Kit (P/N WMK1) or Grifco™ Rotation Bracket (P/N RBK1) can be used to reposition the main control housing. Please contact your local dealer or Chamberlain for more information.

Location of Controller (see left).

Controller has 6 metres of cable with RJ45 ends ready to connect the eDrive™ opener to the controller. eDrive™ Controller Extension Kit (P/N ESK01) is available if needed.

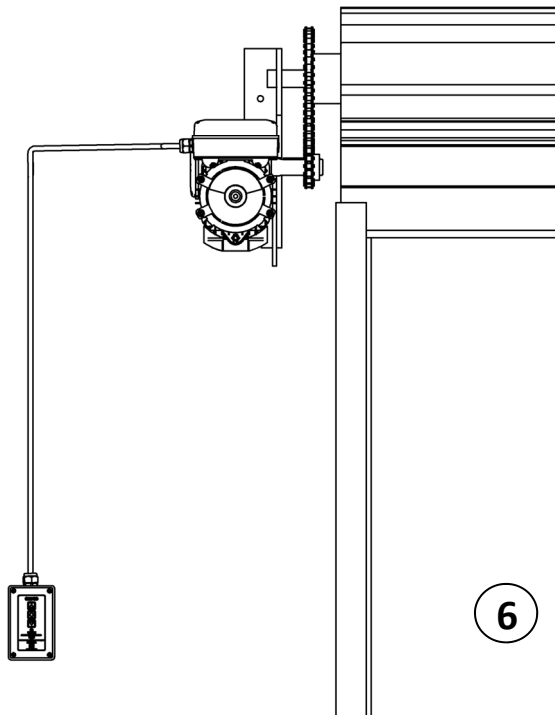

WARNING

When Securing the eDrive™ opener with the 4 x M12 x 40mm long fasteners (based on a 8mm mounting plate) and spring washers provided, it is critical to ensure that the applied torque is between 80-90Nm. When mounting through thicker sections, ensure a minimum of 30mm of screw thread is engaged with the female thread. Use of incorrect fasteners or torque may cause serious product damage, personal injury or death. When fixing through a slotted plate, ensure that the slots are no wider than 13mm as a spring washer may not be adequate in outside diameter to support the hexagon head.

Installing hand chain

Ensure the mounting position allows the hand chain to hang free of obstructions.

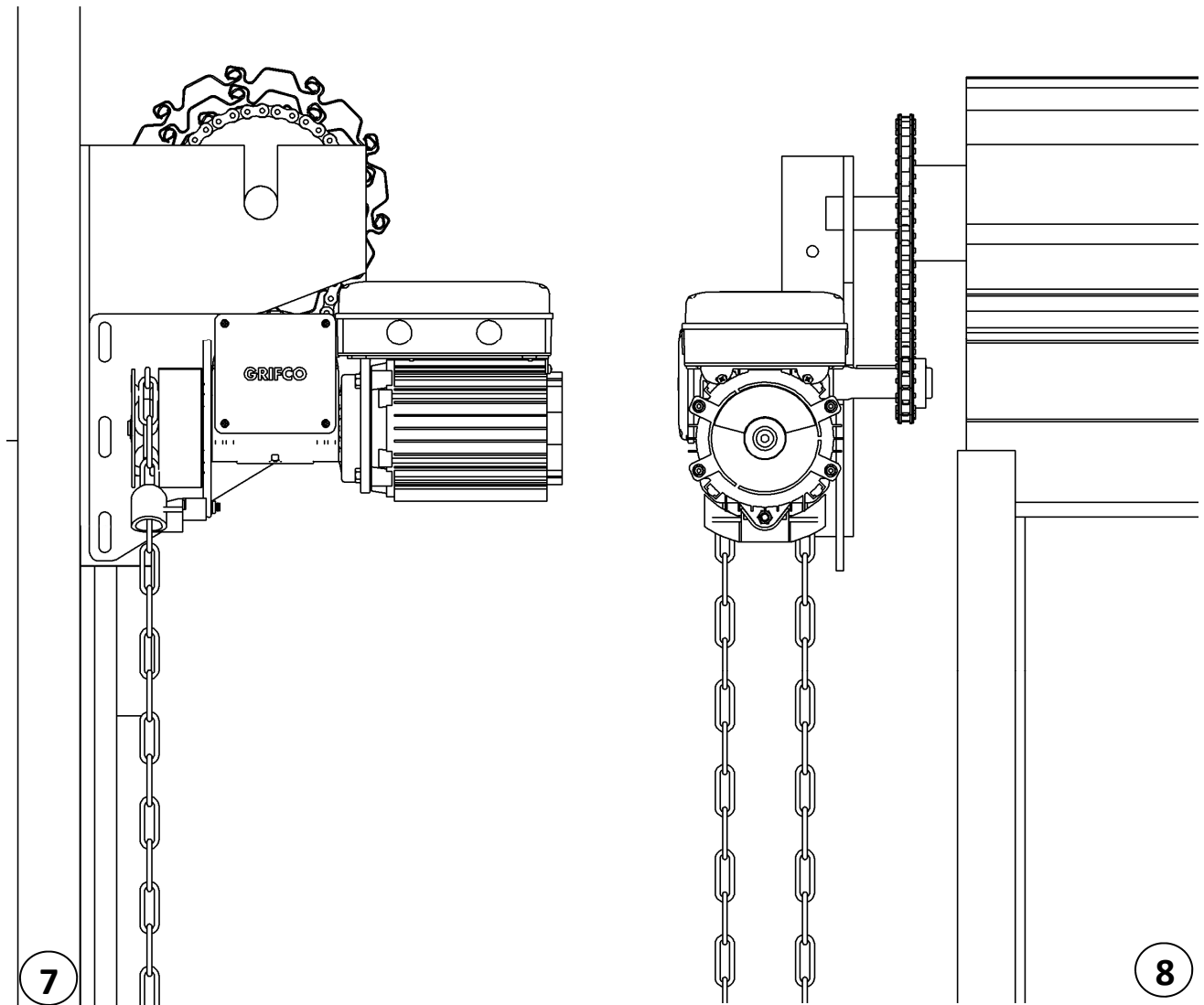

Ensure hand chain is not twisted when making the join!

WARNING

The eDrive™ opener **must**:

- be connected via a device that is capable of being locked for maintenance
- be connected via a suitable circuit breaker that disconnects all live conductors
- be connected in accordance with the wiring rules of the country in which it is installed
- not have control enclosures left open for extended periods (excess dust will void warranty)

Connecting power (if fitted with a plug and lead proceed to next page)

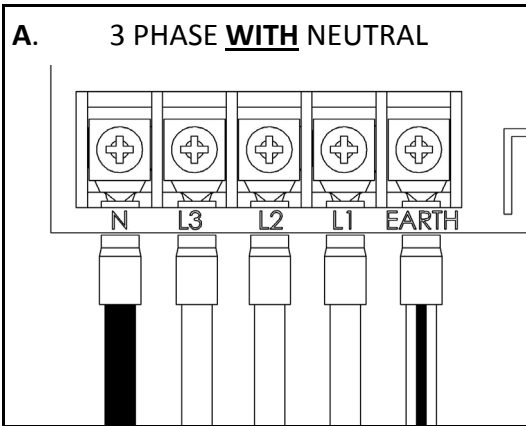

Supply connection for three phase builds with neutral

Models: ML4053, MH4053, ML4103, MH4103, ML4153 & MH4153

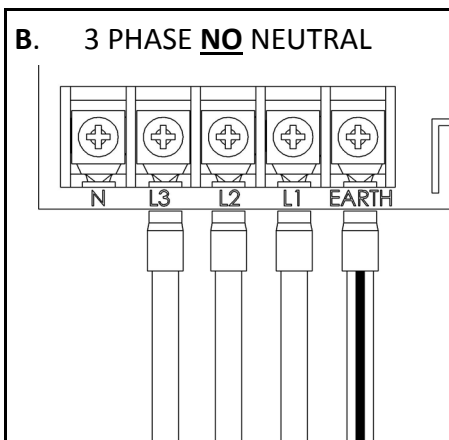
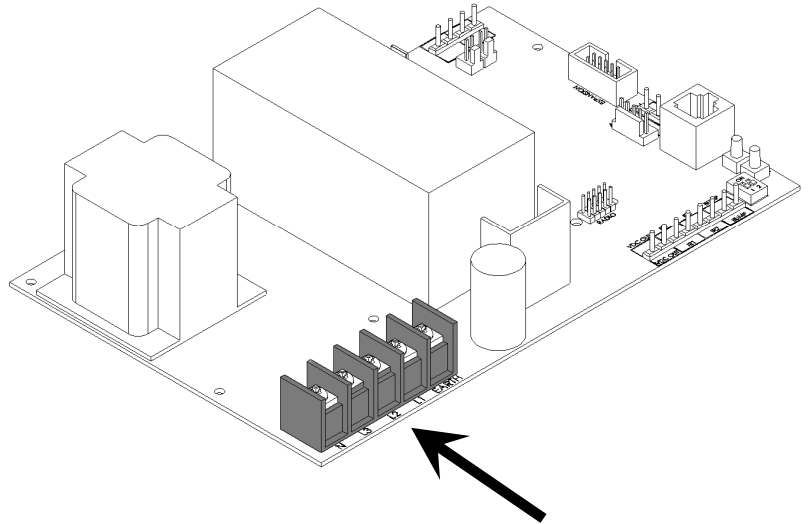

Supply connection for three phase builds **without** neutral

Models: ML4053N, MH4053N, ML4103N, MH4103N, ML4153N & MH4153N

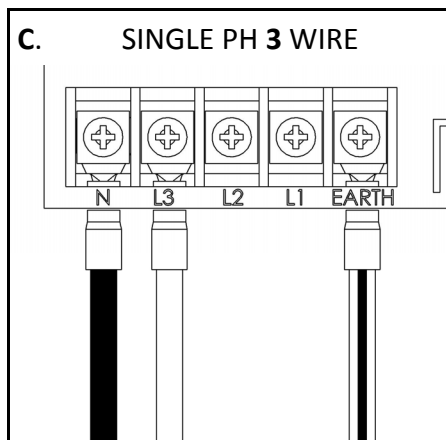

Supply connection for single phase builds 3 wire configuration

Models: ML4051 & ML4101

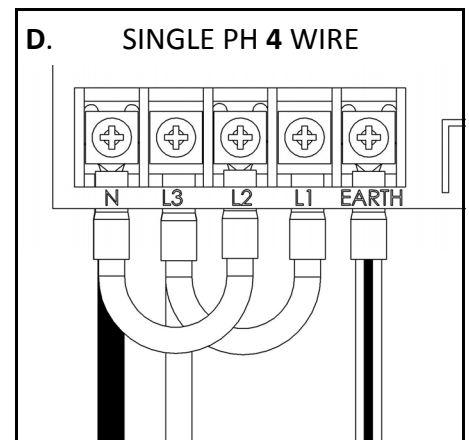

Supply connection for single phase builds 4 wire configuration

Models: ML4102 & MH4102

It is recommended that 1.5mm²(max.) wire size is used to avoid unnecessary crowding and difficulty when making connections. Avoid lengthy cable ends that may cause undue pressure on delicate components. Cable ends should be crimped with fork or loop connectors to ensure a secure fixing in the terminal block.

Note:

- If the supply cord is damaged, it must be replaced by the manufacturer or its service agent or a similarly qualified person in order to avoid a hazard
- A disconnection device incorporated in the fixed wiring must be provided

Controller

The eDrive™ controller is the user interface for the opener. It consists of four buttons for control and setup, as well as three indicators to display the opener status.

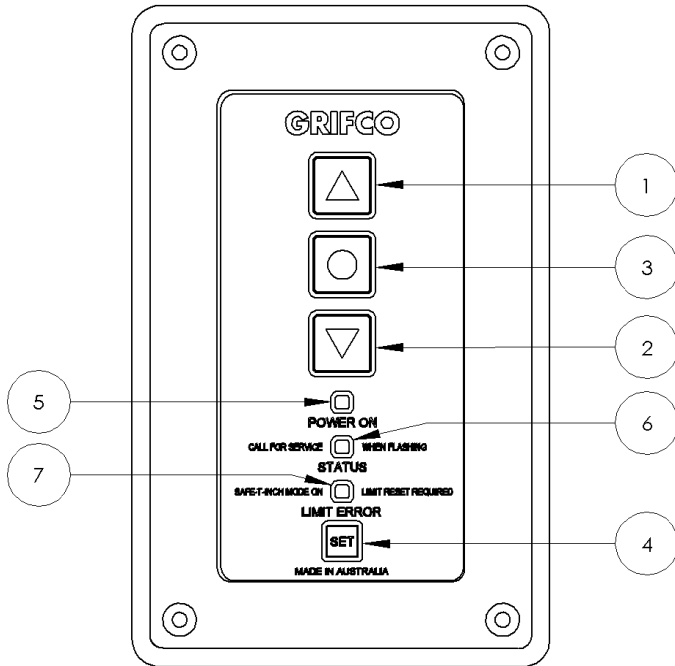

- 1) UP - Moves the door upwards
- 2) DOWN - Moves the door downwards
- 3) STOP - Stops the door
- 4) SET - Used primarily to set limits
- 5) POWER ON - Shows when the unit is mains powered
- 6) STATUS - Shows the status of the unit (refer page 16)
- 7) LIMIT ERROR – When lit indicates limits (or stopping positions) are not set and only SAFE-T-INCH will be active until limits are set. Refer page 11



WARNING

Install the control station where the door is visible. Failure to do so under these circumstances may result in serious injury or death to persons trapped beneath the door.

Installing the controller

The controller is connected to the MCB via a low voltage control cable provided within the controller enclosure. Using the conduit entries provided (also enclosed) run the cable through conduit. Be sure not to cut or damage the cable and therefore cause installation issues and void warranty.

CAUTION: Do not force the controller cable! Excess stretching and manipulation can cause cable failure. Plug ends must not be gripped with pliers.

To connect the controller to the eDrive™ opener, identify the most appropriate entry of the MCB enclosure for your installation. Open the MCB enclosure and fit the conduit fitting, allowing enough cable to reach the controller (RJ45) socket. Place the opposing end of the controller cable through the conduit entry of the controller enclosure and pull through any excess cable. Plug the RJ45 end into the socket located within the controller assembly. Use the space provided within the controller enclosure to neatly coil any excess cable.

Note: If the supplied 6m controller cable is not long enough for your installation, use a Grifco® Controller Extension Kit, available from your local dealer or Chamberlain (P/N ESK01).

Self adhesive pouch

The eDrive™ manual is supplied within a self adhesive pouch. It is recommended that the pouch (along with manual) be attached to a flat surface, easily accessible to service personnel.

The ACEM label (see right) must be fixed in close proximity to the controller e.g. on the door track.



SETUP AND ADJUSTMENT

Once the installation of the opener and controller is complete it is time to test the operation. Make sure the door is away from the ground or the top door stops. This will prevent damage to the door if the direction of the opener is incorrect.

Checking power

Ensure the unit is powered by checking that the *POWER ON* indicator on the controller is lit.

You should also notice that the *LIMIT ERROR* indicator (orange) is lit which signifies that there are no limits set.

Note: Due to the enhanced APE there is no on-board battery used to retain limit positions.



CAUTION

On new installations, the orange limit light should be lit after initial power up. If not, DO NOT operate door unless in limit setting mode or serious damage or injury may occur.

Door direction

Check the direction of the doors movement. If the direction of the door is incorrect, refer below to **Changing door direction**.

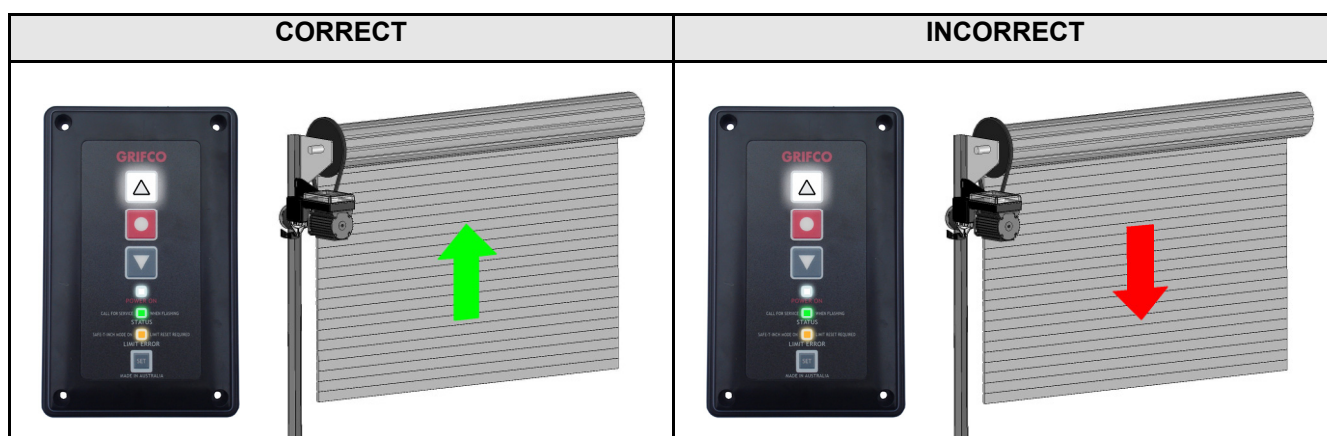

Changing door direction

To change the doors direction first put the unit into 'limit setting mode'. To do this:

1. While holding STOP, press the SET button 3 times.
The *LIMIT ERROR* indicator will start flashing signifying 'limit setting mode'
2. Press and hold STOP for 10 seconds until the LIMIT ERROR indicator flashes quickly.

The direction of the door movement will now be reversed.

The LIMIT ERROR indicator will remain flashing as the unit is still in limit setting mode. You can now set limits (go to step 2 on next page)

Or to exit, press STOP.



WARNING

When removing or replacing jumpers on all circuit boards, mains power must be disconnected.



WARNING

It is important to make sure the door always runs smoothly. Doors which stick or jam must be repaired immediately. Employ a qualified technician to repair the door, never attempt to repair it yourself.

Setting limits

1. While holding STOP, press the SET button 3 times.
The LIMIT ERROR indicator will start flashing signifying 'limit setting mode'
2. Use the DOWN button to drive the door to the desired CLOSED position.
The manual hand chain can be used to accurately position the door before pressing set
3. Press the SET button to save this as the CLOSED position.
The LIMIT ERROR indicator will flash quickly then return flashing slowly
4. Use the UP button to drive the door to the desired OPENED position.
The manual hand chain can be used to accurately position the door before pressing set
5. Press SET again to save this as the OPENED position. The LIMIT ERROR indicator will flash quickly then will go out

The Closed and Open limits have now been set. If at anytime you need to exit 'limit setting mode', just press the STOP button.

Once set, operate the door between limits 2 – 3 times to check they are suitable. If not, return to step 1.

Note: After a power-outage the opener will need to "jog" down then up a small amount in order to re-locate its position. This must be considered when setting limits given any mechanical obstructions that may exist.



WARNING

After the installation a final function test of the system and where present a full function test of the safety devices must be done.

Optional third limit

The Third Limit is a handy option for high doors that rarely need to be fully opened. The third limit is a door position above the open limit position which can be accessed when needed. Having this upper stopping position allows a mid height limit to be set as a first opening point, while a further press of the open button takes the door to a higher set position.

Setting the third limit

Once the Open and Closed limits have been set:

1. Position the door at the open limit position
2. While holding the UP button, press the SET button 3 times.
The LIMIT ERROR indicator will flash
3. Now open the door further until the door is in the desired extended open position
4. Press SET to save this as the extended open position.
The LIMIT ERROR indicator will quickly flash then go out

Accessing the third limit:

1. Open door to first upper limit
2. Press the UP button

OPERATION

To operate the door

Press the UP button on the controller to open the door, press and hold DOWN to close. For optional behavior refer **Setting Door Behaviour** on next page.

Manual operation

The hand chain provided allows manual operation of the door at all times when the motor is not in use. Use of the hand chain during powered operation of the door may result in damage to equipment or injury to the user. Ensure power is shut off before using manual chain.

Standard installation of the eDrive™ Commercial opener is now complete

Please refer to the following for further installation instructions of optional eDrive™ features and / or accessories

DOOR BEHAVIOUR AND OBSTRUCTION DETECTION INPUTS



Use of commercial doors in areas where small children may be present, must comply with the entrapment protection requirements of IEC 60335-2-103. Doors used in industrial areas where only trained persons operate the equipment and small children are never present, may utilise a single means of entrapment protection only.

The eDrive™ is capable of controlling the behaviour of the door in 3 distinct modes depending on its intended use and if it is connected to an obstruction detection device (optional accessories).

Latch up / Inch down mode (default):

The door will travel upwards with only a single press and release of the UP button. The door will stop at the set limit. This mode is **latch up**.

The door will only travel downwards when the DOWN button is held. The door will stop at the closed limit or when the button is released. This mode is **inch down**.

Inch up and down mode:

The door will only travel whilst the UP or DOWN buttons are being held. The door will stop at the limits or when the button is released. To set this mode set refer table on next page.

Latch up and down mode:

Note: This mode is only possible in conjunction with an Obstruction Detection Device such as an Infrared (IR) Beam or a Safety Bump Edge. Failure to do so may result in damage to property or injury to persons.

The door will travel upwards and downwards with only a single press and release of the UP or DOWN button. The door will stop at the set limit or when the STOP button is pressed. To set this mode refer table on next page.



Do not place hands or tools near the opener when power is on or when testing controls or safety devices.

Always disconnect power before servicing or adjusting the opener.

Setting door behaviour

To set the door behaviour modes, adjust the DIP switches in the corner of the MCB shown below. The different combinations suit different behaviours and obstruction detection devices installed.

Dip switch **1** is used to latch **DOWN** and switch **2** is used to latch **UP**.

At default the MCB is set to latch open and inch close, shown right. The door will open with a single press but only travel downwards while the down button is being held. For details on the 3 distinct modes refer to previous page.

***The door must only be set to latch DOWN if there is suitable obstruction detection installed. Failure to do so can lead to serious injury or death.**

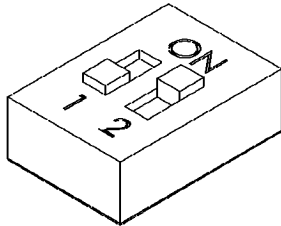
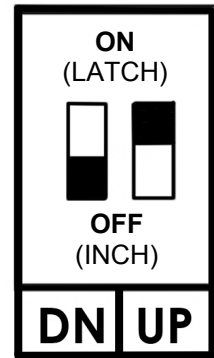

Latch up / inch down

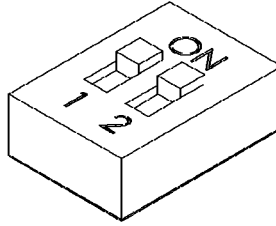

*Latch up / latch down

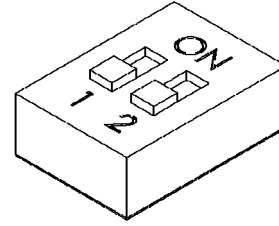

**Inch up / inch down

Note: **Both dials must be OFF (inch up / inch down) for Coles & BI-LO electrically operated roller door installations or when opener height is less than 2.5m from the ground without sufficient guarding of moving parts.

WARNING

To reduce risk of injury or damage it is strongly recommended that an Infrared Beam and / or Safety Bump Edge be used in conjunction with the opener. Failure to do so can lead to serious injury or death.

Installing obstruction detection devices (requires Terminal Blocks P/N TB210 - refer below)

Devices such as Infrared (IR) Beams and Safety Bump Edges allow safe automatic or latch closing of the door and can be wired directly into the MCB via an appropriate cable entry. The devices are wired into the obstruction inputs located next to the door behaviour dip switches on the MCB.

VDC OUT: Supply power for PB008 & PB060 only. (24VDC, max *150mA)

IR1: Pulsing (monitored) signal or NC (normally closed) switching input

IR2: Pulsing (monitored) signal or NC (normally closed) switching input

For more detailed information on installation refer to IR Beam manual

BUMP: Bumper edge input - Resistor (monitored) type

- Pulsing (monitored) IR Beam P/N C77
- NC switching IR Beam P/N PB008 or PB060

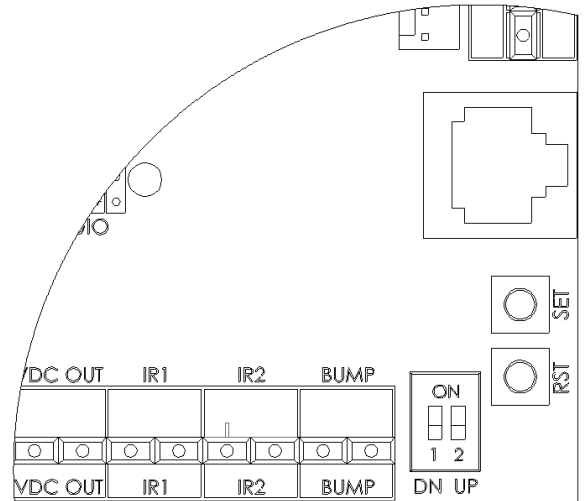

Note: Pulsing or monitored obstruction detection devices will be automatically learned by the opener. Normally closed obstruction detection devices require one simulated obstruction to be learned by the opener. Once learned, latch closing will be allowed when set.

Note: The eDrive™ features “constant pressure to close”. This means that if an obstruction detection device fails, the opener can still ‘inch down’.

WARNING

All automatic devices such as loop detectors, timers, remote receivers etc must be connected to an Expansion Board (optional accessory). They should never be connected directly to the controller unless in direct line of sight of the door. Failure to do so under these circumstances may result in serious injury or death to persons trapped beneath the door

Additional switchgear / accessories

Caution! Any access control intended for these terminals must be user operated and in line of sight with the door.

The eDrive™ can be easily interfaced by the reverse side of the controller push button panel (Refer to adjacent diagram). To do so you will need terminal blocks (P/N TB210) available from your local commercial door dealer or Chamberlain®.

Note: A controller must always be plugged in (refer pg 15 no. 2) for the opener to function. When utilising the AUTO or ESTP terminals the respective bridge must be removed, refer right.

Note: Additional 24VDC devices must not draw current from the MCB in excess of 150mA. Excessive load from connected devices will cause malfunction of the eDrive™ opener. For additional loads, use a separately mounted power supply.

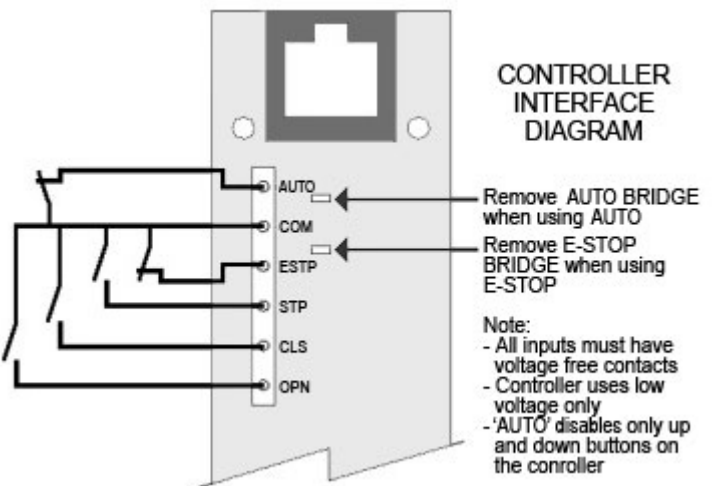

WARNING

Keep additional accessories away from children. Do not allow children to play with pushbuttons or remote controls. Without safety devices a door can cause serious injuries as it closes. Only trained people are allowed to use the opener.

MAIN CONTROL BOARD (MCB)

The MCB is the heart of the eDrive™. The diagram below provides an overview of the major components and access points.

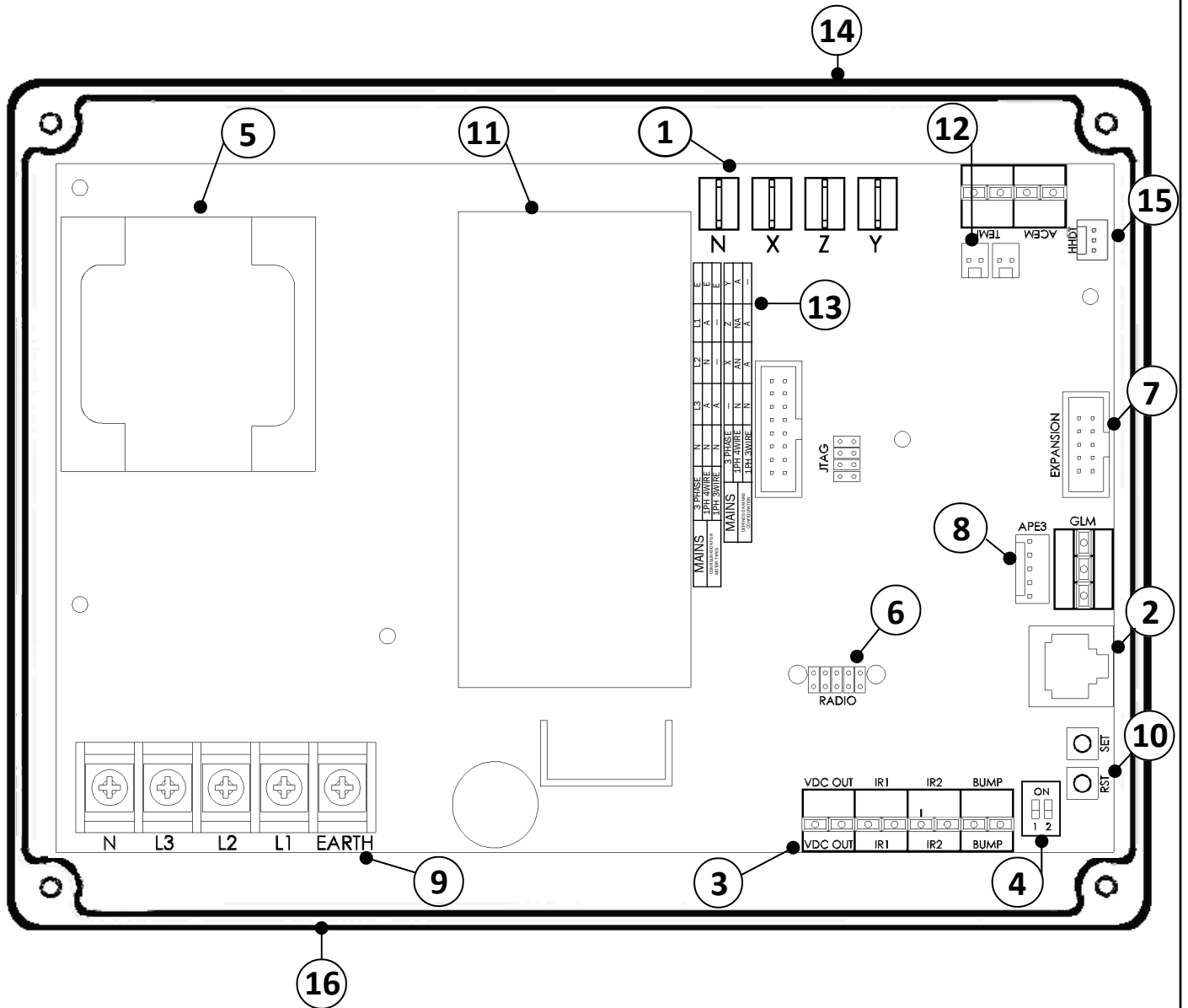

1	Motor terminals	9	Power supply terminals
2	Controller connection socket	10	'Reset' and 'Set' buttons
3	Obstruction Detection inputs	11	Mechanically interlocked contactors
4	Door behaviour Dip Switches	12	Motor temperature cut-out connector
5	Transformer	13	Mains & Motor connection tables
6	Remote Control Card input	14	Controller cable entry (typical)
7	'Elite' Expansion Board Input	15	HHDT input (diagnostic tool)
8	APE limit terminal	16	Mains power cable entry (typical)

Note: MCB layout may vary depending on build type.

TROUBLESHOOTING

Status Indicator (Green) Flash / Problem Table

No. flashes/ Problem	Meaning	Possible causes	Possible Solutions
Solid ON	Motor running		
2	Infrared beam and/or Bump edge obstruction N/C beam removed	IR beam obstructed Bumper edge pressed The opener has detected removal of an obstruction device	<ul style="list-style-type: none"> • Clear obstruction • Remove pressure from bump edge • Set DIP 1 to OFF and press 'reset' (RST) button on MCB for 3 seconds. Relearn any remaining obstruction detection devices
3	Obstruction detection device removed	The opener has detected removal of an obstruction detection device	<ul style="list-style-type: none"> • Set DIP 1 to OFF and press 'reset' (RST) button on MCB for 3 seconds. Relearn any remaining obstruction detection devices
4	MCB error	Internal Error	<ul style="list-style-type: none"> • Power off, and on. If un-resettable replace MCB
5	EB internal error	EB disconnected or ignored from MCB	<ul style="list-style-type: none"> • Return EB to the installation or resolve EB issue, refer Elite Manual
9	APE error 1 APE error 2	APE position jump Severe close range frequency APE cable disconnected APE cable fault	<ul style="list-style-type: none"> • Replace APE assembly • Press 'reset' (RST) button on MCB for 3 seconds • Reconnect APE cable • Replace APE cable
10	Under speed error	Extreme load on door	<ul style="list-style-type: none"> • Check for objects causing interference to door operation • Check door installation • Check for damage to motor • Upgrade to a larger opener
12	Thermal overload	Motor overheating	<ul style="list-style-type: none"> • Use opener less frequently • Upgrade to a high cycle opener
14	Direction error	Motor connections altered	<ul style="list-style-type: none"> • Change door direction and reset limits
15	Clutch slip (if fitted) No speed detected Contactor failure	Clutch adjustment set too low Motor stalled Extreme vibration or impact during transit	<ul style="list-style-type: none"> • Check clutch adjustment • Check door for mechanical failure or motor fault • Replace MCB
Constant flash	Due for service	Door is due for routine service	<ul style="list-style-type: none"> • Contact your local door dealer to arrange service
No Lights Displayed	Power failure – No lights on MCB or Controller *With lights on at MCB	Power supply not correctly connected *Bad connection to Controller	<ul style="list-style-type: none"> • Check transformer • Check power supply wiring • *Refer below if lights are on at MCB and not on Controller
Push button not responding	Opener does not drive up and / or down	Bad connection to Controller Damaged Controller cable Controller buttons forced and dislodged from rear of lid	<ul style="list-style-type: none"> • *Check RJ45 plugs are clipped in securely at Controller and MCB • *Check connections • *Replace Controller cable • *Replace Controller
Open or Close button not responding but green light comes on	Coil failure or incorrect motor wiring if green light on whilst holding up or down button and opener does not move in one direction	Extreme vibration or impact during transit Incorrect motor terminal connection	<ul style="list-style-type: none"> • Replace MCB • Correctly wire the motor

IMPORTANT NOTE:

If a problem is found with an installation, be sure to read the troubleshooting guide thoroughly and if the problem persists call Chamberlain for technical assistance on **1800 638 234** or email **customerservice@chamberlainanz.com**

HAVING A PROBLEM?

Power must be turned OFF before servicing or adjusting the opener!

1. No indicator lights on wall control:

- Are there any indicator lights ON the MCB (Main Control Board)?
YES... Check connection between MCB and wall control
Check for damage to control cable
NO... Check power supply

2. Power light illuminated on wall control but door will not go up:

- Does the green status light come ON when button is being pressed?
YES... Check for loose motor terminal connection. If green light begins to flash refer '**Troubleshooting**' (pg.16)
NO... Check for control circuit isolating switch or connection between MCB and wall control
Check for damage to control cable

3. Power light illuminated on wall control but door will not go down:

- Is the green status light flashing **2** or **3** times?
YES... 2 times - check for obstructions or IR beam misalignment
3 times - check for persistent IR beam obstruction, misalignment or bump edge wiring problem
Check for correct wiring connection and DIP switch settings on MCB
NO... *continue onto next question*
- Does the green status light come ON when down button is being pressed?
YES... Check for loose motor terminal connection. If green light begins to flash refer '**Troubleshooting**' (pg.16)
NO... Check for control circuit isolating switch or connection between MCB and wall control
Check for damage to control cable

4. Can't set limits:

- Does the orange light start flashing after third press of the 'set' button?
YES... But green status light starts to flash 'x' times while attempting to set upper limit. Refer '**Troubleshooting**' (pg.16)
NO... Ensure all external devices and external push buttons are disconnected from wall control
Check for damage to control cable

5. Opener activates from wall control but not remotes:

- Are limits set?
YES... Change remote battery. If using Expansion board check key switch position is in auto and check MCB and Expansion board DIP switches are set correctly. Check that remote is learned and receiver card is picking up signal
NO... Set limits. **Note: there is a 30 second delay between using wall control and remotes when using an Expansion Board without a dedicated auto and manual mode setting**

6. Opener will only travel around 200mm either way:

- Are limits set? i.e. orange limit light ON = limits not set
YES... Check damaged to control cable
NO... Set limits. Refer page 11. If unable to set limits refer to above no. 4

7. Works from wall control but automatic functions do not: (only applicable when using an Expansion Board)

- Is there a solid orange (COMS) light on the Expansion Board?
YES... MCB (Main Control Board) must be reset. Call Chamberlain (1800 638 234) for resetting procedure
NO... Make sure key is in correct position

8. Power light intermittently goes OFF and ON:

- Is the power light going off on the MCB also?
YES... Check supply wiring
NO... Check connection between MCB and wall control
Check for damage to control cable

MAINTENANCE

The eDrive™ is equipped with smart logic to indicate when your commercial door will require servicing. When the STATUS indicator flashes constantly please contact your commercial door dealer to arrange a routine door service.

Certain mechanical aspects of the installation must be checked, see below:

Monthly

- Check chain alignment, tension and condition. Adjust / replace if required *
- Check PE / IR beam/s and bump edge functionality where applicable

Quarterly

- Check tightness of fixing bolts and (sprocket) grub screws. Adjust if required * refer page 6
- Check correct electrical operation
- Check manual operation via hand chain
- Lubricate the drive chain *
- Check door balance. The drive chain should display a transition of tension from one side of the linkage to the other in the lower half of the roller door travel. This transition is the 'balance' point. Adjust if required *
- Conduct door maintenance in accordance with door manufactures guidelines. This will include door balance *

* SERVICE MUST BE CARRIED OUT BY A QUALIFIED TECHNICIAN

To view total cycles (limits must be set)

- Drive to door to closed limit.
- Press and hold CLOSE for 10 seconds.
- After 10 seconds and while still holding CLOSE, press and release the SET button.
- Status LED will light up indicating number of cycles performed.

To read number of cycles, follow the 'Reading Status Flashes' routine described below.

Reading Status Flashes

- STATUS indicator will start flashing to signify to value of the least significant digit of the overall number, or in the case of amperage values this will be the value after the decimal point. A solidly lit indicator stands for zero.
- Press set to view the next digit.
- Continue previous step until the STATUS indicator flashes quickly for 1 second then goes out. This signifies that the entire number has been displayed.

To reset error

(This process indicates there has been a severe problem. Persistent resetting will void warranty and may damage the door and/or opener). This procedure will only work when the status light is flashing **4, 5, 9, 10, 14** or **15** times.

- Hold the STOP button for 10 seconds
- While still holding the STOP button, press and release the SET button

The STATUS indicator should flash quickly for 1 second. Any errors that were flashing should have stopped.

HHDT (Handheld Diagnostic Tool)

The HHDT allows you to view numerous statistics and information including, total cycles, cycles since service, viewing software version, number of transmitters programmed and load reversals.

The input can be found in the corner of the MCB adjacent to the ACEM terminal, refer pg 15 no. 15.

The diagnostic tool is also used to enable the service cycle alert (refer HHDT manual for procedure). Unlike the previous **Maestro™** builds the **eDrive™** service cycle alert is disabled at default.



ACCESSORIES

Remote control kit (optional)

Upgrade your commercial door opener to remote control with this inexpensive kit featuring two x 4 channel hand transmitters & plug-in receiver card. **P/N CGK844**

Note: An Obstruction Detection Device such as an Infrared Beam (PB008 or C-77) and / or Safety Bump Edge (AWEXXK) must be installed in order to close the door from the remotes.

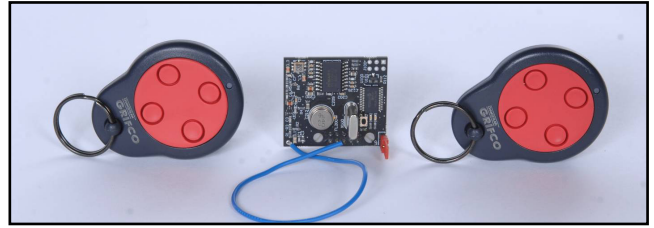

Remote keypad and receiver (optional)

For extra security add a receiver card (R) & remote keypad (KP) to this opener anytime after installation (no wiring). **P/N's MRC2 (R) + C840 (KP)**

Note: An Obstruction Detection Device such as an Infrared Beam (PB008 or C-77) and / or Safety Bump Edge (AWEXXK) must be installed in order to close the door from the remotes.

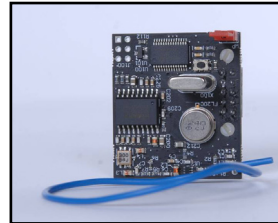

Battery back up (optional)

Battery back up is now available on all 3 phase 415v Grifco® openers up to 2hp and single phase 240v to 1hp. With automatic changeover, these units are ideal for those who need an uninterrupted power supply.

P/N BBU1500—3 phase 415v

P/N CGPS2KA—1 phase 240v



IR beam and remote control kit (optional)

Combine Chamberlain's CGK844 hand transmitter and receiver kit with the C77 Infrared (IR) beam for a cost effective upgrade to your eDrive™ electronic opener. The send / receive IR beam allows for a latching circuit (pulse to open, pulse to close) and will reverse the door when obstructed on closing.

P/N CGK844PB



Elite Expansion Board upgrade kit (Optional)

This Grifco® Expansion Board is a full featured addition to any eDrive™ opener, turning the standard eDrive™ into the eDrive™ Elite. This hardware adds more features to the unit, giving more options and more control.

Some features include:

- 4 relay outputs for controlling external devices
- Auto close with adjustable delay time
- Control over obstruction behaviour
- Programmable trigger input
- Connection to a variety of radio cards
- Other inputs for advanced door behaviour

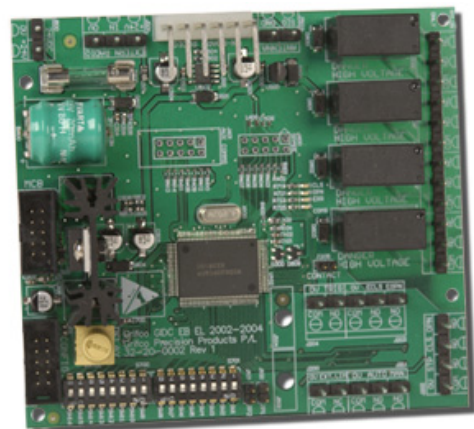

* The Expansion Board is the heart of the Elite upgrade

The premium version (typically used for car parks) features a controller with Auto / Man key switch, metal housing, 0-8 metre Infrared Beam, and Remote Control Kit. **(P/N E41D41)**

CHAMBERLAIN 24 MONTH LIMITED WARRANTY

(Excluding electric motors)

Chamberlain Australia Pty Limited / Chamberlain New Zealand Limited (**Seller**) warrants to the original purchaser of the Grifco® product (**Unit**) that it is free from defects in material and/or workmanship for a period of 24 months from the date of first purchase from the Seller.

If, during the limited warranty period, the Unit fails due to defects in materials or workmanship Chamberlain will, provided the defective part or Unit is returned freight and insurance prepaid and well packaged to the nearest Chamberlain office, undertake to repair or, at its option, replace any defective part or Unit and return it to the Buyer at no cost. Repairs and replacement parts are warranted for the remaining portion of the original warranty period.

Limited warranty on electric motors - 12 months

In keeping with the manufacturer's warranty, Chamberlain offer a 12 month warranty on all electric motors from the date of purchase. We will furnish a replacement motor free of charge, if it is found to be defective. Labour costs may apply.

Where the Unit has been installed by an authorised installer, Chamberlain will furnish replacement parts free of charge through the authorised installer. Warranty is based on the electric motor/opener being used in conjunction with controls supplied (or other controls authorised in writing prior to installation) by Chamberlain.

In-warranty service

During the warranty period, if the product appears as though it may be defective, call our technical department before removal of the unit. A Chamberlain technician will diagnose the problem and promptly supply you with the parts for "do-it-yourself" repairs, or provide you with shipping instructions for a factory repair or replacement.

If our service centre determines that a warranty claim has been made in respect of a failure or defect arising under or out of any exclusion set out below, we may charge you a fee to repair and/or return the unit to you.

Exclusions

This warranty does not cover any failure of the Unit due to:

1. non-compliance with the instructions regarding installation, operation, maintenance and testing of the Unit or of any product with which the Unit is used.
2. any attempt to repair, dismantle, reinstall or move the Product to another location once the Product is installed by any person other than an authorised installer.
3. tampering, neglect, abuse, wear and tear, accident, electrical storm (force majeure), excessive use or conditions other than normal commercial use.

This warranty does not cover any problems with, or relating to, the commercial door or door hardware, including but not limited to the door slats, door springs, door drum, door alignment or hinges, any problems caused by electrical faults or labour charges for reinstalling a repaired or replaced Unit.

Liability – Australia only

Under no circumstances shall the Seller be liable for consequential, incidental or special damages arising in connection with the use, or inability to use, the Unit. In no event shall the Seller's liability for damages or injury arising from breach of law or contract or for negligence, exceed the cost of repairing or replacing the Unit or refunding the purchase price of the Unit.

Under Division 2 Part V of the *Trade Practices Act, 1974*, certain warranties and conditions (**Implied Terms**) are implied into contracts for the supply of goods or services if the goods or services are of a kind ordinarily acquired for personal, domestic or household use or consumption. Liability for breach of those Implied Terms cannot be excluded or limited and the limitations and exclusions above do not apply to the Implied Terms.

Except for the Implied Terms and the warranties set out above, the Seller excludes all warranties and conditions implied by statute, at law, in fact or otherwise.

Liability – New Zealand only

Except as set out in the *Fair Trading Act 1986* and the *Consumer Guarantees Act 1993*:

- a) all other guarantees, warranties and representations in relation to the Unit or its supply are excluded to the extent that the Seller can lawfully exclude them; and
- b) under no circumstances shall the Seller be liable for consequential, incidental or special damages arising in connection with the use, or inability to use, the Unit, other than those which were reasonably foreseeable as liable to result from the failure.

Chamberlain reserves the right to change the design and specification without prior notification. Some features or accessories may not be available in certain markets or areas.